



# New Brunswick™ Products

Operating Manual M1192-0050 Revision V+

The enclosed Operating Manual was originally produced by the New Brunswick Scientific Company, Inc.

#### **About Eppendorf**

Eppendorf is a biotech company which develops, produces and distributes systems for use in life-science research laboratories worldwide. After more than 60 years the vision of the company is just as valid and up-to-date as it ever was: our goal is to improve the living conditions of man. Since 1945 we have succeeded in continually producing high-quality products and technology, integrated as systems which solve problems in a holistic way. Information about Eppendorf is available online at: [www.eppendorf.com](http://www.eppendorf.com)

#### **About New Brunswick Scientific**

New Brunswick Scientific, purchased by Eppendorf in 2007, was founded in 1946 and is a global leader in the design and manufacturing of advanced biotechnology equipment. New Brunswick Scientific's innovative systems are used in a broad range of research and commercial applications, spanning biomedical, environmental, food and cosmetic sciences. With the world's largest selection of lab shakers and a comprehensive line of fermentors, bioreactors, CO2 incubators and freezers, New Brunswick Scientific is proud to support the groundbreaking advances of its customers worldwide. Information about New Brunswick Scientific is available online at: [www.newbrunswick.eppendorf.com](http://www.newbrunswick.eppendorf.com)

For information related to warranty or service, please contact your local Eppendorf sales organization or distributor: [www.eppendorf.com/worldwide](http://www.eppendorf.com/worldwide)

Eppendorf® and the Eppendorf logo are registered trademarks of Eppendorf AG, Germany. New Brunswick™ is a trademark of Eppendorf AG, Germany. All rights reserved, including graphics and photos. Copyright © 2013.

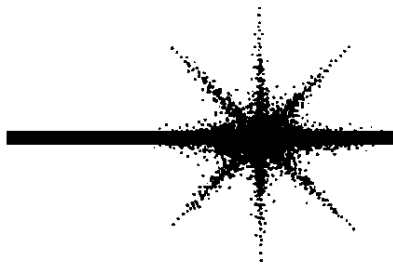

# Guide to Operations

## ***innova*<sup>TM</sup> 4000/4080**

### **Digital Incubator Shaker**

MANUAL NO: M1192-0050  
Revision V  
August 5, 2002

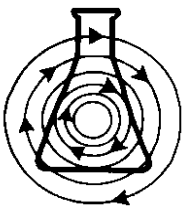

---

## **NEW BRUNSWICK SCIENTIFIC CO., INC.**

**BOX 4005 • 44 TALMADGE ROAD • EDISON, NJ 08818-4005**

**Telephone: 1-732-287-1200 • 1-800-631-5417**

**Fax: 732-287-4222 • Telex: 4753012 NBSCO**

**Internet: <http://www.nbsc.com> • E-mail: [bioinfo@nbsc.com](mailto:bioinfo@nbsc.com)**

---



---

## **INTERNATIONAL OFFICES:**

### **THE NETHERLANDS**

New Brunswick Scientific BV  
Kerkenbos 1101, 6546 BC Nijmegen  
P.O Box 6826, 6503 GH Nijmegen  
Holland  
Tel: 31 (0)24 3717 600  
Fax: 31 (0)24 3717 640  
E-mail: sales@nbsbv.nl

### **FRANCE**

New Brunswick Scientific SARL  
3, rue des Deux-Boules  
75001 Paris  
France  
Tel: 33 (0)1 4026 2246  
Fax: 33 (0)1 4026 5423  
E-mail: sales@nbssarl.fr

### **UNITED KINGDOM**

New Brunswick Scientific (UK) Ltd.  
Edison House, 163 Dixons Hill Road  
North Mymms, Hatfield, Herts. AL9 7JE  
United Kingdom  
Tel: 44 (0)1707 275733  
Fax: 44 (0)1707 267859  
E-mail: bioinfo@nbsuk.co.uk

### **BELGIUM**

New Brunswick Scientific NV/SA  
't Veldeke 1  
B-1970 Wezembeek-Oppem  
België/Belgique  
Tel: 32 (0)2 731 6787  
Fax: 32 (0)2 731 8130  
E-mail: sales@nbsnv-sa.be

### **GERMANY**

New Brunswick Scientific GmbH  
In Der Au 14  
D-72622 Nürtingen  
Deutschland  
Tel: 49 (0)7022 932490  
Fax: 49 (0)7022 32486  
E-mail: sales@nbsgmbh.de

### **CHINA**

New Brunswick Scientific Co., Inc.  
9A. AiBang Building  
585 LingLing Road  
Shanghai 200030, P.R. China  
Tel: 86 21 6481 2658  
Fax: 86 21 6481 2665  
E-mail: nbschc@online.sh.cn

**THIS PAGE INTENTIONALLY BLANK**

**CAUTION!**

This equipment *must* be operated as described in this manual. If operational guidelines are not followed, equipment damage and personal injury *can* occur. Please read the entire User's Guide before attempting to use this unit.

**THIS PAGE INTENTIONALLY BLANK**



---

## Copyright Notice

New Brunswick Scientific Company, Inc.  
Box 4005 44 Talmadge Road  
Edison, New Jersey 08818-4005

© Copyright 2002 New Brunswick Scientific Co., Inc.

All Rights Reserved.

Reproduction, adaptation, or translation without prior written permission  
from

New Brunswick Scientific is prohibited.

## Disclaimer Notice

New Brunswick Scientific Co., Inc. reserves the right to change  
information in this document without notice. Updates to information in  
this document reflect our commitment to continuing product  
development and improvement.

## Manual Conventions



**NOTE:**

**Notes contain essential information that  
deserves special attention.**



**CAUTION!**

**Caution** messages appear before procedures  
which, if caution is not observed, could result  
in damage to the equipment.

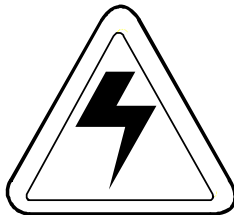

**WARNING!**

**Warning** messages alert you to specific  
procedures or practices which, if not followed  
correctly, could result in serious personal  
injury.

**Bold**

**Text in bold face type emphasizes key words or  
phrases.**

**THIS PAGE INTENTIONALLY BLANK**



## WARRANTY

Innova shakers are warranted by New Brunswick Scientific Co., Inc. for two years or 10,000 hours of actual shaker use, whichever comes later. This warranty covers parts and labor for the entire machine, with the exception of glassware and its contents. This warranty covers faulty components and assembly, and our obligation under this warranty is limited to repairing or replacing the shaker or part thereof which shall, within two years after date of shipment or 10,000 hours of operating time, whichever comes later, prove to be defective after our examination. **This warranty does not cover any loss of time, materials or biological or biochemical by-products caused by any work interruption resulting from shaker failure, nor does it extend to any Innova shaker which has been subjected to misuse, neglect, accident or improper installation or application. In addition, the warranty does not apply to any Innova shaker that has been repaired or altered outside the NBS factory without prior authorization from New Brunswick Scientific Co., Inc.** After 10,000 hours of operating time have elapsed, the Innova warranty may still be in effect as long as the two-year minimum warranty period has not been reached. Operating time is based on actual usage of the shaker, as determined by the shaker's internal electronic clock. Any tampering or alteration of the electronic clock will void the 10,000 hour warranty.

**THIS PAGE INTENTIONALLY BLANK**

# TABLE OF CONTENTS

<b>1</b>	<b>INTRODUCTION .....</b>	<b>1</b>
<b>2</b>	<b>OVERVIEW .....</b>	<b>3</b>
2.1	GENERAL DESCRIPTION .....	3
2.2	UNIVERSAL POWER CAPABILITY.....	5
2.3	CONTROL PANEL.....	6
2.3.1	<i>LED Display</i> .....	6
2.3.2	<i>User Interface Keys</i> .....	7
2.3.3	<i>Status Indicator Lights</i> .....	7
2.3.4	<i>Function Indicators</i> .....	8
2.4	PLATFORM ASSEMBLIES .....	8
2.5	AVAILABLE OPTIONS .....	8
2.6	HEAVY-DUTY CONSTRUCTION FEATURES .....	9
2.6.1	<i>Triple Eccentric Drive</i> .....	9
2.6.2	<i>Bearings</i> .....	10
2.6.3	<i>Motor</i> .....	10
2.6.4	<i>Electronic Boards</i> .....	10
<b>3</b>	<b>INSTALLATION .....</b>	<b>11</b>
3.1	UNPACKING AND INSPECTION .....	11
3.2	VOLTAGE CONFIGURATION.....	11
3.3	SPACE REQUIREMENTS .....	12
3.4	HOSE CONNECTIONS .....	12
3.5	ELECTRICAL CONNECTIONS .....	14
3.6	PLATFORM INSTALLATION .....	14
3.7	FLASK CLAMP INSTALLATION.....	15
<b>4</b>	<b>OPERATION.....</b>	<b>17</b>
4.1	STARTING THE UNIT.....	17
4.2	CONTINUOUS (UNLIMITED) RUN.....	17
4.3	CHECKING SETPOINTS.....	18
4.4	TIMED FUNCTIONS .....	18
4.5	ALARM FUNCTIONS .....	19
4.6	TEMPERATURE .....	19
4.7	TEMPERATURE OFFSET CALIBRATION .....	20
4.8	TOTAL RUNNING TIME.....	21
4.9	VENT .....	21
<b>5</b>	<b>SERVICE &amp; MAINTENANCE .....</b>	<b>23</b>
5.1	ROUTINE MAINTENANCE .....	23
5.2	CLEANING.....	23
5.3	CHANGING FUSES .....	24
5.4	CHANGING VOLTAGES .....	24
5.5	REPLACING THE BELT .....	25
5.6	REPLACING THE MOTOR ASSEMBLY .....	26
5.7	MAINT INDICATOR ON .....	27
5.8	RECORDER ADAPTATION .....	28
5.9	COOLING COIL KIT RETROFIT INSTALLATION.....	29
5.10	ESD PRECAUTIONS .....	31
5.11	REPLACING THE MAIN CONTROL BOARD.....	31
5.12	REPLACING THE TEMPERATURE CONTROL BOARD .....	33

5.13 INSTALLING THE QUICK CHANGE PLATFORM OPTION ..... 34

5.14 GASSING MANIFOLD RETROFIT INSTALLATION ..... 35

**6 APPENDIX ..... 37**

6.1 SPECIFICATIONS ..... 37

6.2 AVAILABLE PLATFORMS ..... 39

    6.2.1 *Easy Load Platform Option*..... 39

    6.2.2 *Interchangeable Platforms*..... 39

6.3 SERVICE PARTS LIST ..... 40

6.4 ACCESSORIES ..... 41

    6.4.1 *Retrofit Option Kits* ..... 41

    6.4.2 *Accessory Flask Clamps*..... 41

    6.4.3 *Clamp Mounting Hardware Kits*..... 41

**7 DRAWINGS..... 43**

7.1 CONTROL SCHEMATIC ..... 43

7.2 LIST OF ILLUSTRATIONS ..... 48

**8 INDEX ..... 49**







# 1 INTRODUCTION

*This Manual is intended to provide you with a complete understanding of how to use the Innova 4000/4080 Digital Incubator Shaker. It will acquaint you with its basic components and provide information about preventative maintenance and service issues. This manual also includes a complete guide to the installation and operation of the Innova 4000/4080.*

*The manual is divided into four basic sections. Chapters 1-2 provide an overview of your Innova 4000/4080 and all of its features and options. Chapters 3-4 detail the set-up and operation of the instrument. Chapter 5 outlines maintenance and service procedures which should be utilized only by a qualified service engineer, as well as routine maintenance for your use. Finally, Chapters 6-8 provide additional information of interest: specifications, service and accessory part numbers, a list of drawings and an index of important terms used in this manual.*

***We highly recommend that you completely familiarize yourself with this guide prior to operating the Innova 4000/4080.***

The Innova 4000 Digital Incubator Shaker will provide you with reliable and maintenance-free operation which is characteristic of all NBS shakers. The Innova 4000 is among the newest generation of NBS Shakers and incorporates a variety of state-of-the-art components and features to permit the precision operation necessary for your exacting scientific experiments.

The Innova 4080 Digital Incubator Shaker has all the same features and controls as the Innova 4000, but it also has an expanded temperature range, from 5.0°C above ambient to 80.0°C (high temperature).

**All references in this manual to the Innova 4000 also apply to Innova 4080 unless otherwise noted.**

**THIS PAGE INTENTIONALLY BLANK**

---

## 2 OVERVIEW

### 2.1 *General Description*

The Innova 4000 Shaker incorporates a triple eccentric counter balanced drive to provide horizontal plane rotary motion in a 3/4" (19 mm) circular orbit. A Proportional/Integral (PI) Microprocessor controller with instantaneous digital feedback controls the speed over a range of 25-500 RPM. It also provides temperature control over a range of 5°C above ambient to 60°C.; the Innova 4080 high temperature model provides temperature control over a range of 5°C above ambient to 80°C. For lower temperatures an optional cooling coil is available. The internal chamber is 19¾ inches (50.2 cm) wide, 13¼ inches (33.6 cm) above the platform, and 19 inches (48.3 cm) deep.

The shaker may be operated either continuously, or in a timed mode via a programmable timer for shaking periods of 0.1 hour to 99.9 hours.

The Innova 4000 is equipped with audible and visible alarms which are activated when an alarm condition exists, as follows:

- The end of a timed run
- Deviations of shaking speed or temperature outside of tolerance limits

A wide variety of platforms can be used with the Innova 4000. Dedicated platforms are available for a variety of flask sizes. A Universal platform and test tube racks are also available (*see Section 6.4 for Accessories*).

Additionally, the Innova 4000 has analog outputs for a chart recorder to record speed and/or temperature. *See Section 5.6 for Recorder Adaptation.*

Figure 1 and Figure 2 below show the front and rear views of the Innova 4000.

For safe operation, the Innova 4000 is provided with a safety switch which automatically stops the shaker mechanism when the lid is lifted. Additionally, the lid can be operated with one hand. The lid latches when fully opened for your security; an upward lifting motion deactivates the latch for closing the lid.

A gassing manifold kit is also available for use with the Innova 4000 Shaker.

**Figure 1 Front View**

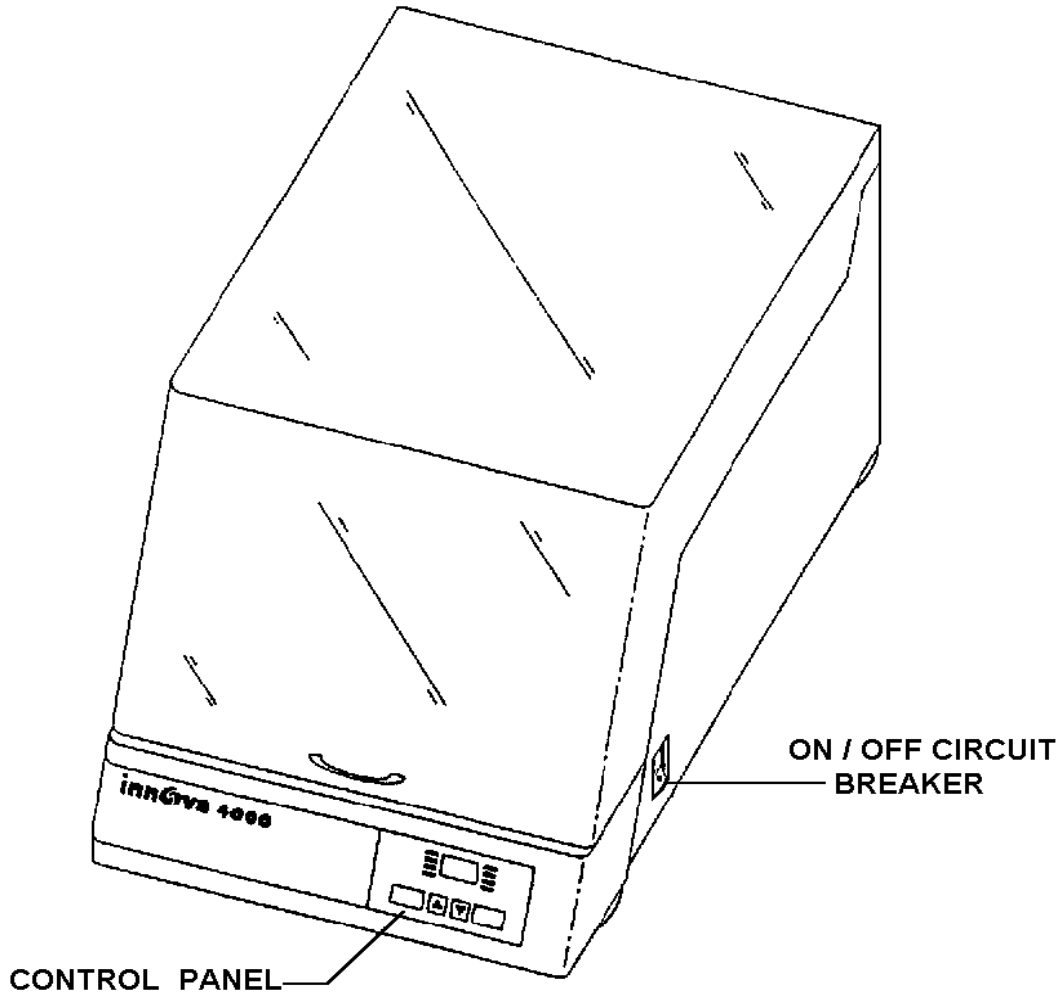
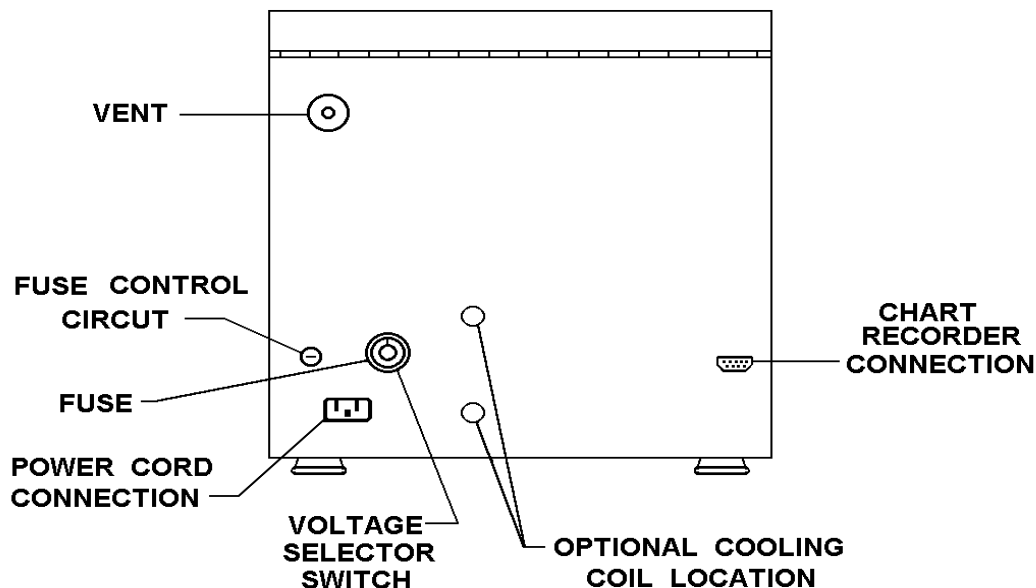

Figure 2 Rear View



## 2.2 Universal Power Capability

A voltage selector switch is used to select the appropriate voltage. This universal system adapts to worldwide power requirements. Voltage has been set prior to shipment.

Innova shakers are available in 100V, 120V, 220V and 240V versions, and accommodate both 50 and 60 Hz frequencies.



### **WARNING!**

It is **critical** to check the voltage setting before plugging the unit in to a power source.

Confirm the voltage setting by checking the voltage selection on the voltage selector switch (Figure 2) against the voltage listed on the Caution label located over the power cord connection.

If necessary, refer to Section 5.2 on Changing Voltages.

## 2.3 Control Panel

The control panel (*see figure 3 below*), which is located on the front of the instrument, serves as the operator interface. The keypad has four keys marked START/STOP,  $\Delta$ ,  $\nabla$  and SELECT. A three-digit LED display provides numeric values and some letter codes.

There are also four function indicator lights and four status indicator lights on the control panel. A general description of the display, the user interface keys and the indicator lights follows. For operation of the control panel, *see Section 4*.

### 2.3.1 LED Display

The display on the Innova control panel is a 3-digit LED display. During normal shaker operation the display will indicate:

- Shaker status (on/off)
- Shaking speed
- Setpoints
- Hours remaining (timed run)
- Measured temperature
- “Lid” (cover open & shaker operation stops)

**Figure 3 Control Panel**

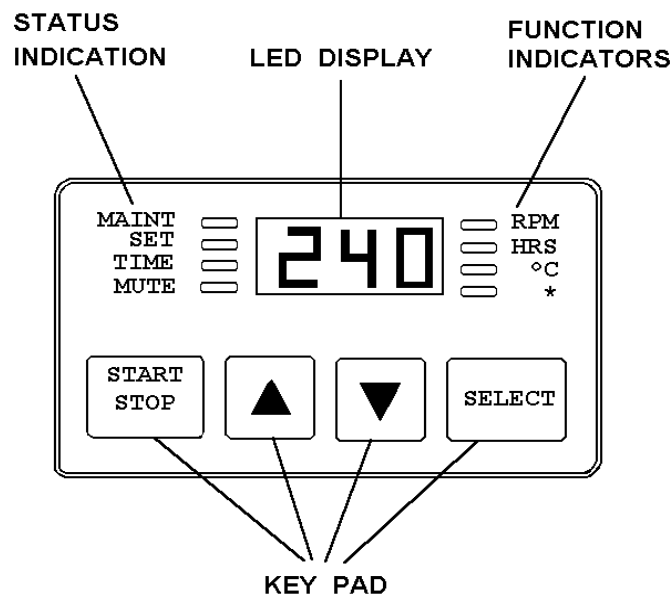

---

### 2.3.2 User Interface Keys

There are four touch-sensitive buttons on the keypad (*see Figure 3*):

#### START/STOP

This key is used to start or stop the shaking motion. It will also activate or stop the timer when a timed run is desired.

#### SELECT

This key is used to change the displayed parameter.

#### Δ

This key is used to adjust upward the setpoint of a displayed parameter. In conjunction with the ∇ key, it also allows the user to enter the Set mode for setpoint changes.

#### ∇

These keys are used to adjust downward the setpoint of a displayed parameter. In conjunction with the Δ key, it also allows the user to enter the Set mode for setpoint changes.

### 2.3.3 Status Indicator Lights

There are four status indicator lights to the left of the LED display (*see Figure 3*). They are:

- **MAINT:** remains lit after 10,000 hours of use. Accumulated running time is internally monitored and may be displayed as a guideline.
- **SET:** indicates that the shaker is in the Set mode, in which setpoints are displayed and can be altered.
- **TIME:** indicates that the timer is in operation. Innova shakers can be programmed to run for a preset time from 0.1 hour to 99.9 hours without stopping an ongoing run. The timer can be disengaged or reset.
- **MUTE:** indicates the status of the audible alarm. When the Mute indicator is illuminated, the audible alarm device is disabled.

### 2.3.4 Function Indicators

There are four function indicator lights to the right of the LED display (*see Figure 3*). They indicate the current parameter being displayed:

- RPM: revolutions per minute
- Hours: time remaining
- °C: temperature (in degrees Celsius)

### 2.4 Platform Assemblies

The Innova 4000 can be used with a wide variety of NBS 18 inch x 18 inch (46 cm x 46 cm) platforms, which will accept a variety of clamps for flasks and test tubes (*see Section 6.4.2*).

### 2.5 Available Options

These options can be ordered for factory installation, or for field retrofit by an NBS authorized technician (*see Section 6.4 for part numbers*).

- **Cooling Coil:** The Innova 4000 can be ordered with an installed cooling coil. The cooling coil provides the ability to operate at temperatures below ambient.
- **Gassing Manifold:** The Innova 4000 can be ordered with an installed gassing manifold. The gassing manifold allows introduction of gas into flasks on the shaker platform.
- **Quick Change Platform:** The Innova 4000 can be ordered with a Quick Change Platform. This enables the user to snap in platforms without tools or hardware (M1192-9901). It is recommended for speeds up to 400 RPM.



## 2.6 Heavy-Duty Construction Features

### 2.6.1 Triple Eccentric Drive

The Triple Eccentric Drive (see Figure 4 below) is used in the Innova Shakers employs the same proven technology which has driven New Brunswick Scientific's shakers for over 30 years. This drive mechanism utilizes a counterweight system to stabilize the rotary motion produced during operation. When the workload moves in one direction, opposing forces are generated to stabilize the shaker. This action will help eliminate the problem of walking which may occur with less precisely balanced instruments. Vibration is minimized and the life of the unit is extended.

**Figure 4 Counterbalanced Drive Mechanism**

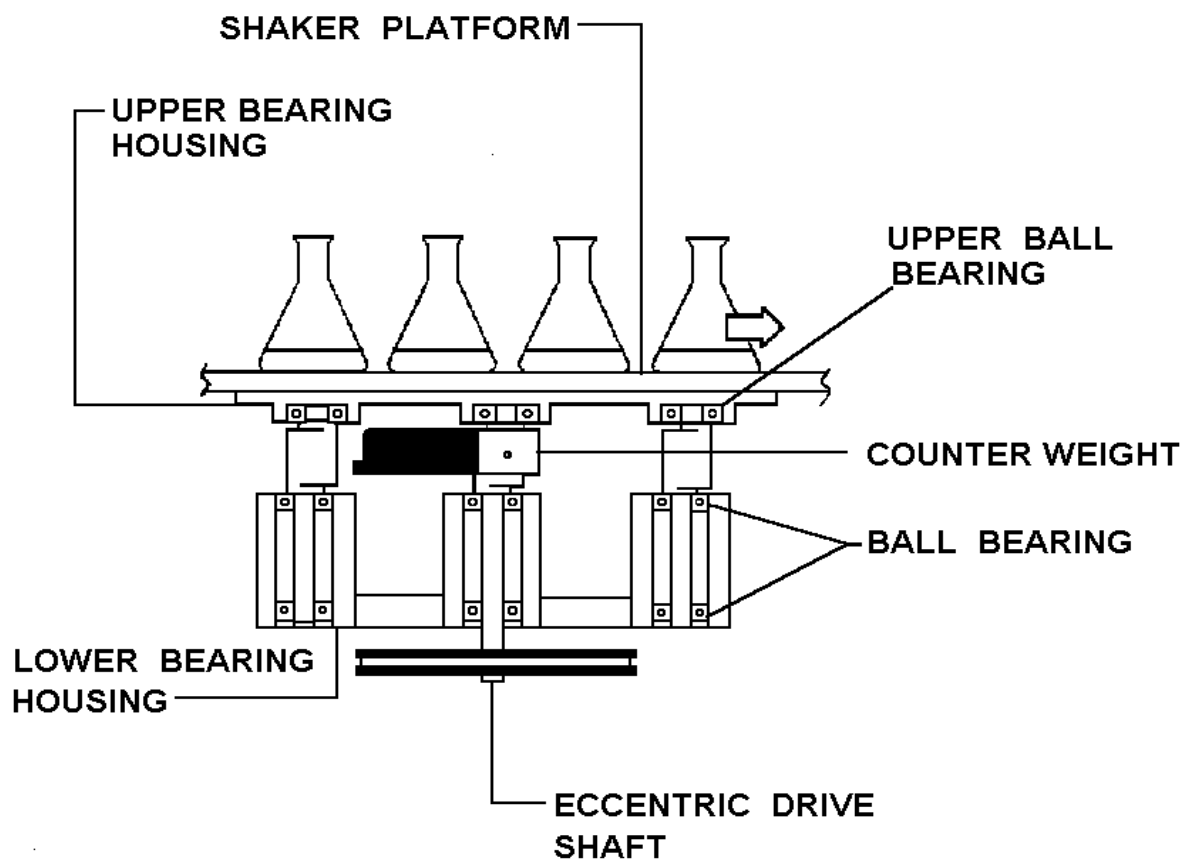

## 2.6.2 Bearings

Innova shakers employ sealed, lubricated ball bearings of the highest quality. Sealed bearings minimize the generation of airborne particulates which may be disadvantageous in clean rooms or controlled environment areas. These bearings require no maintenance.

## 2.6.3 Motor

The Innova 4000 Shaker uses a 3-phase brushless ball bearing DC motor. This low profile motor provides high torque along with quiet, efficient operation and low maintenance. The motor has a rating of 1/15 horsepower.

## 2.6.4 Electronic Boards

The Main Control board for the Innova shaker has the following functions:

- Non-volatile memory for storage of key parameters during power interruption
- Speed sensing, electronic commutation and power control for the brushless DC drive motor
- Maintains an elapsed running time clock
- Contains firmware for shaker control as well as recognition of an expansion connector for option modules
- Provides an operator interface via displays, audible alarm and connection to the keypad module (keypad buttons and display graphics).

The Temperature Control module for the Innova shaker has the following functions:

- Control of analog power supplies
- Rectification and regulation for analog power supplies
- Provides signal conditioning circuitry and A/D conversion for the RTD-based temperature measurement
- Provides remote monitoring capabilities by supplying analog output for speed and temperature which are compatible with chart recorders and analog data acquisition system
- Controls the heater.

## 3 INSTALLATION

*The Innova 4000 is a versatile instrument which can be operated in a continuous fashion or set for a timed run. The following section describes set-up and installation procedures.*

### 3.1 Unpacking and Inspection

Upon unpacking the unit, inspect it carefully for any damage which may have occurred during transit. Report any apparent damage to the carrier and to New Brunswick Scientific's Service Department (call toll-free 1-800-631-5417 in the United States). Save the crate and packing materials.

### 3.2 Voltage Configuration

Determine the voltage of your unit by checking the voltage selector (*see Figure 2*) and the label on the rear of the unit. Confirm that the correct electrical service package is included with the unit by comparing the part number on the electrical service package to the following table (*also see Section 5, Service & Maintenance*).

<b>VOLTAGE CONFIGURATION TABLE</b>		
	<b>Catalog #</b>	<b>Electrical Service Package #</b>
<b>Innova 4000</b>	M1192-0001, 100V 50/60 Hz	M1192-0070
	M1192-0000, 120V 50/60 Hz	M1192-0070
	M1192-0002, 220V 50/60 Hz	M1192-0071
	M1192-0003, 240V 50/60 Hz	M1192-0071
<b>Innova 4080</b>	M1192-0005, 100V 50/60 Hz	M1192-0070
	M1192-0004, 120V 50/60 Hz	M1192-0070
	M1192-0006, 220V 50/60 Hz	M1192-0071
	M1192-0007, 240V 50/60 Hz	M1192-0071



#### **NOTE:**

**Use of the Innova Shakers requires a platform, which is a separate item. See the Available Platforms list in Section 6.2.**

### 3.3 Space Requirements

It is essential that the shaker be situated in an area where there is sufficient space for the unit and its service lines (see *Figure 5*).

The dimensions of the Innova 4000 are:

<b>Width</b>	21 inches	53.4 cm
<b>Depth</b>	27½ inches	69.9 cm
<b>Height</b>	19¾ inches	50 cm

The effective surface area required for operation is:

<b>Width</b>	23 inches	58.4 cm
<b>Depth</b>	30 inches	76.2 cm

### 3.4 Hose Connections



#### NOTE:

**If a cooling coil has been factory-installed, follow the procedure below to make the appropriate connections, referring to Figure 2.**

Eight feet of reinforced rubber hose and clamps are provided for connection to the coolant or water supply.

1. Cut the hose into two pieces to suit a water supply and drain length requirement.
2. Attach the two hoses to the cooling coil connection tubes with two clamps, allowing 1/8 to 3/16 inch of hose to extend beyond the clamps.
3. One line must go to an open drain or return to a coolant supply, and the other line must be connected to a water or coolant supply.



#### NOTE:

**If the unit is using tap water as the coolant, it is preferable that the supply hose be attached to a supply valve, to minimize water use.**

**Figure 5 Space Requirements**

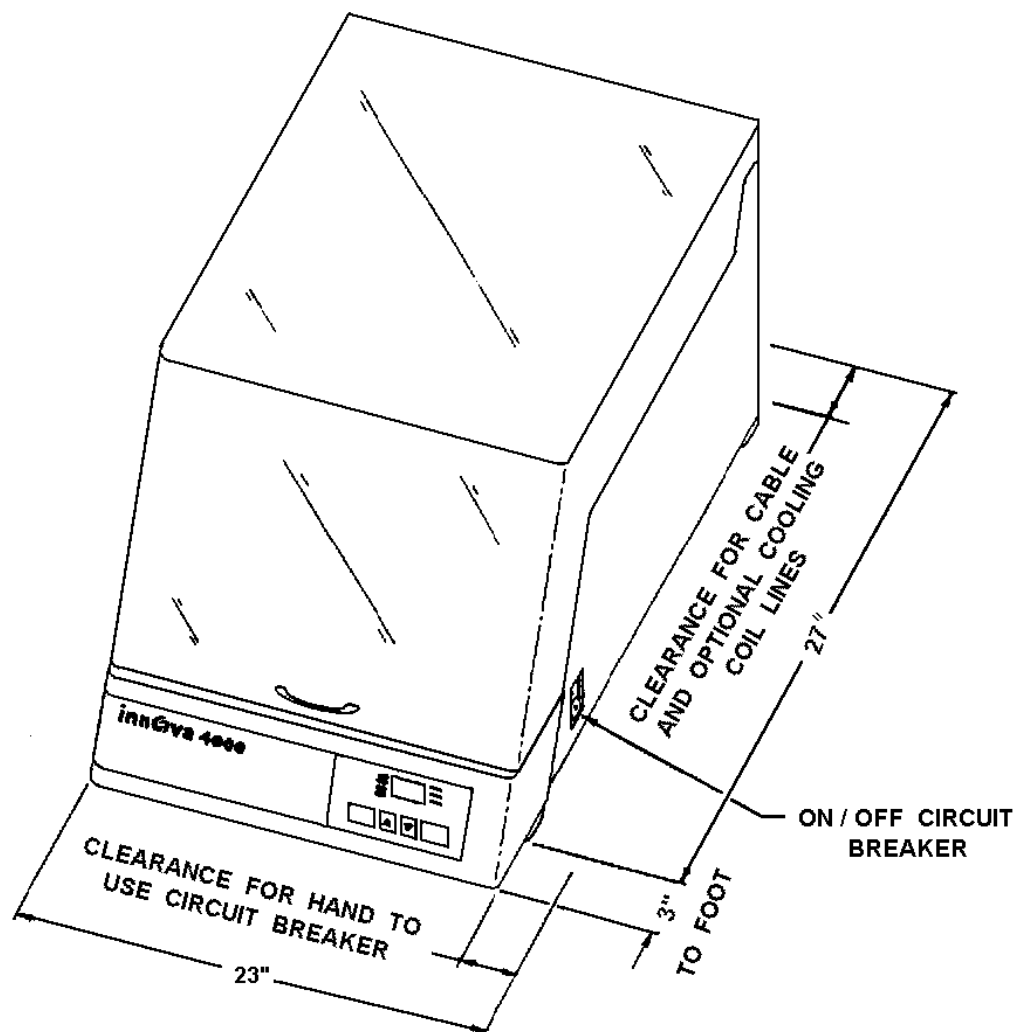

### 3.5 *Electrical Connections*

**CAUTION!**

Before making electrical connections, be sure to check the following:

1. Check the voltage selector switch at the rear of the unit to ensure that it is set to the appropriate voltage.
2. Remove the caution label from the rear of the unit.
3. Set the circuit breaker on the right side of the unit to the OFF position.

**ONLY THEN:**

4. Connect the line cord to the Power Cord Connection and to a grounded electrical outlet.

**CAUTION!**

A grounded electrical outlet is necessary for the safe operation of this instrument.

### 3.6 *Platform Installation*

A platform must be installed on the unit prior to use.

1. Set the power switch in the off position. Open the cover.
2. The unit is shipped with the platform screws installed in the subplatform of the bearing housing. These screws must be removed before a platform can be installed. Using the 5/32" hex wrench provided, loosen and remove the platform screws from the bearing housing.
3. Place the platform on the on the subplatform of the bearing housing.
4. Reinstall and secure the four Allen head (+) platform screws with the 5/32" hex wrench provided to secure the platform.

If the Quick Change Option is installed:

1. Slip the platform between the side guides and push the platform to the rear retainer.

2. Press down on the front edge of the platform. The platform should snap down into place and be retained by the springs. Check that the rear edge of the platform is engaged under the bend of the rear clip.

**NOTE:**

**Recommended for speeds up to 400 RPM.**

### 3.7 *Flask Clamp Installation*

Flask clamps purchased for use with universal platforms require installation. Clamps are installed by securing the base of the clamp to the platform with the correct type and number of screws (refer to clamp hardware application charts below). All clamps are shipped complete with hardware. Clamps for 2- to 6-liter flasks are shipped with an additional girdle to keep the flasks in place.

To install 2- to 6-liter clamps, follow these steps (*see Figure 6*):

1. Place clamp on platform, secure in place with correct type of screws (refer to clamp hardware application charts below).
2. Place the loose girdle around the upper portion of clamp body so that it is held in place by the legs of the clamp.
3. Insert the flask into the clamp.



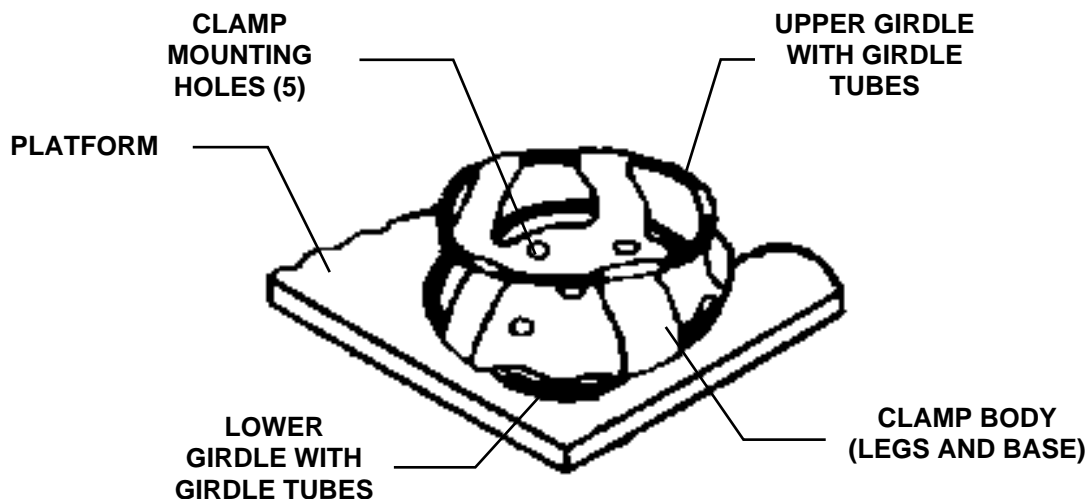
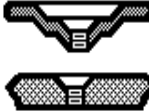

**Figure 6 2- to 6-Liter Flask Clamp Installation**









**NOTE:** 2800 ml Fernbach Flask Clamp is applicable to the above.

NBS flask clamps are used on a variety of shaker platforms. Flat head screws of different lengths and thread pitch are used to secure the clamp. The following tables identify the proper screw for your shaker application by reference to the head style.

### 10 to 500 ml Clamp Hardware Application Chart

<i>Description</i>	<i>Part Number</i>	<i>Qty.</i>	<i>Application</i>
 10-24 x 5/8 (15.87 mm) flat Phillips (+) head screw	S2116-3101	1	3/4" (19.05 mm) thick wood platform 
 10-24 x 5/16 (7.9 mm) flat Phillips (+) head screw	S2116-3051	1	5/16" (7.9 mm) thick aluminum, phenolic and stainless steel platforms. 
 10-32 x 5/16 (7.9 mm) flat slotted (-) head screw	S2117-3050	1	all stainless steel platforms 

### 1- to 6-Liter Clamp Hardware Application Chart

<i>Description</i>	<i>Part Number</i>	<i>Qty.</i>	<i>Application</i>
 10-24 x 5/8 (15.87 mm) flat Phillips (+) head screw	S2116-3101	5	3/4" (19.05 mm) thick wood platform 
 10-24 x 5/16 (7.9 mm) flat Phillips (+) head screw	S2116-3051	5	5/16" (7.9 mm) thick aluminum, phenolic and stainless steel platforms. 
 10-32 x 5/16 (7.9 mm) flat slotted (-) head screw	S2117-3050	5	all stainless steel platforms 



#### **NOTE:**

**2800 ml Fernbach Flask Clamps are applicable to the above chart.**



## 4 OPERATION

### 4.1 *Starting the Unit*

To start the instrument initially, push the ON/OFF switch on the right side of the shaker to the ON position.



#### **NOTE:**

- The LED will be flashing to indicate that the shaker has been off or the power to the shaker has been interrupted. To stop the flashing display, press any key.
- Press the SELECT key until the RPM indicator lights. If the shaker is running, the LED display will track the speed as it accelerates to the most recently entered setpoint. The shaking action may be stopped or started by pressing the START/STOP key.
- The shaker motor stops when the cover is opened. While the cover is open, and the display mode is RPM, the display will indicate “LID”.
- At the higher speed ranges, it is recommended that the platforms have a 50% minimum load to maintain a good balance condition.

### 4.2 *Continuous (Unlimited) Run*

To set the shaker for continuous run:

1. If the LED displays “OFF”, press the START/STOP key .
2. Press SELECT until RPM is lit.
3. Press either  $\Delta$  or  $\nabla$  to enter SET mode (the SET indicator will light).
4. Set the speed by using the  $\Delta$  or  $\nabla$  keys until the desired setpoint is displayed.



#### **NOTE:**

**Holding the  $\Delta$  or  $\nabla$  key down will cause the setting to change more rapidly:**

The setpoint may be changed during a run without stopping the shaker by following Steps 2-4. During speed changes, the alarm will flash until the speed returns to within 5 RPM of the setpoint.

### 4.3 *Checking Setpoints*

1. Press SELECT until the desired indicator is lit.
2. Press either  $\Delta$  or  $\nabla$  to enter the SET mode and to display the current setpoint.



#### **CAUTION!**

**Holding the  $\Delta$  or  $\nabla$  key for more than 0.5 second causes the speed, time or temperature setpoint to change. Should this occur, reset the setpoint.**

### 4.4 *Timed Functions*

The shaker may be programmed to stop automatically after a preset time period of 0.1 hour - 99.9 hours. Power must be supplied to the shaker in order to set the timer. A timed run, however, can be initiated while the unit is either shaking or stopped.

To set the timer:

1. Press the SELECT key to light HRS.
2. Set the time by pressing the  $\Delta$  or  $\nabla$  key until the desired setpoint is displayed (0.1 - 99.9 hours).
3. To start the timer operation, press the  $\Delta$  or  $\nabla$  key once. The SET indicator should light.
4. While the SET indicator is on, press the START/STOP key. The time indicator will light and remain lit for the duration of the run. At the end of the timed run the display will read "OFF", the time indicator will flash, and the audible alarm will sound (if it is enabled).
5. The setpoint may be changed during a run without stopping the shaker by following steps 1 and 2.

To stop the alarm: Press the SELECT key and change to any other function.

To cancel the timer **without** stopping the shaker:

1. Repeat steps 1 and 2.

2. While the set LED is lit press the START/STOP key. The Time indicator will go out and the display will read “OFF”.

#### 4.5 Alarm Functions

Innova 4000 has an audible alarm which is activated at predetermined times. It may be deactivated in the following way:

1. Press SELECT to light HRS.
2. **Simultaneously** press the  $\Delta$  and  $\nabla$  keys. The SET and MAINT indicators will flash.
3. While the SET and MAINT indicators are flashing, press the START/STOP key. The MUTE indicator will light to advise that the audible alarm has been deactivated.

Reactivate the alarm by repeating steps 1-3. The MUTE indicator will be extinguished when the alarm has been reactivated.

#### 4.6 Temperature

This control consists of an internal electrical interface, an RTD temperature probe, and an analog output for chart recorder or computer. The temperature can be set from 4.0°C to 60.0°C on the Innova 4000 or from 4.0°C to 80.0°C on the Innova 4080.

To set the temperature:

1. Press the SELECT key until the °C function indicator lights.
2. Use the  $\Delta$  or  $\nabla$  key to increase or decrease the setpoint.

The temperature alarms, both audible and flashing light, are activated if the temperature is more than 1.0° C above or below the temperature setpoint. The alarm will automatically deactivate as the unit achieves the set temperature.



#### NOTE:

**The shaker may be started or stopped by pressing the START/STOP key. When starting, the unit will automatically return to the last function and setting. The alarms will be activated until the speed is within 5 RPM and/or the temperature is within 1.0° C of their respective setpoints. The alarm will not sound when the shaker is accelerating or the temperature is changing to satisfy a new setpoint.**

## 4.7 Temperature Offset Calibration

The temperature probe and the temperature controller are calibrated together at the factory. The temperature probe measures the temperature of the air at the probe's location, near the heat exchanger return vent. The controller uses the probe input to adjust air temperature, up or down, to match the temperature setpoint.

Depending on various conditions within the chamber, such as flask placement and size, the heat produced by growing organisms, heat losses due to liquid evaporation from flasks, etc., the display temperature may differ from temperatures within the flasks themselves.

If you wish to have the temperature display ("Indicated Temperature") match the temperature at a given point, or match the average of a series of points within the chamber ("Actual Temperature"), proceed as follows:

1. Let the unit equilibrate at or near the desired temperature. Record the Indicated Temperature.
2. Record the Actual Temperature.
3. Calculate the temperature correction value:  $\text{Actual Temperature} - \text{Indicated Temperature} = \text{Temperature Correction Value}$ .
4. Press the SELECT key until the °C function indicator illuminates.
5. Simultaneously press the  $\Delta$  and  $\nabla$  keys. The SET and MAINT indicators will light.
6. While the SET and MAINT indicators are illuminated, use the  $\Delta$  or  $\nabla$  key to set the display to the calculated Temperature Correction Value.



### NOTE:

**The °C light will pulse rapidly for a short duration to indicate it is not operating in the factory default mode. It will pulse for a longer duration and less rapidly (with a frequency of approximately one second) to indicate temperature is more than one degree above or below setpoint.**

To return to the factory calibration:

1. Press the SELECT key until the °C function indicator illuminates.
2. Simultaneously press the  $\Delta$  and  $\nabla$  keys. The SET and MAINT indicators will light.
3. While the SET and MAINT indicators are illuminated, press the START/STOP key.

## 4.8 **Total Running Time**

The control module of the Innova 4000 totalizes the time the shaker has been “ON” to track hours of usage. To display the accumulated running time:

1. Select HRS using the Select key.
2. Simultaneously press the  $\Delta$  and  $\nabla$  keys.

The SET and MAINT indicators will flash and the accumulated running time will be displayed in hundreds of hours (i.e., “02” equals 200 hours; “102” equals 10,200 hours). This display will continue for 10 seconds and then default to the previous mode readout.

After 10,000 hours of operation, the MAINT indicator will light. Preventive maintenance is recommended at this point. The light can be deactivated by NBS service personnel. Alteration of the internal clock by unauthorized personnel will void the warranty.

## 4.9 **Vent**

The Innova 4000 is provided with a vent (*see Figure 2*) to exhaust gas or allow small amounts of ambient air into the chamber. The vent is located in the rear upper left side of the cabinet. When the knob is tight in a clockwise position then the vent holes are sealed. Rotating the knob counter-clockwise opens the vent.

**THIS PAGE INTENTIONALLY BLANK**

## 5 SERVICE & MAINTENANCE

*The following section describes basic maintenance, troubleshooting and service procedures. It also provides instructions to retrofit optional features in the field.*

*With the exception of changing fuses or changing voltage, any of these operations must be performed by a qualified service engineer.*

### 5.1 Routine Maintenance

The Innova Shaker requires no routine mechanical maintenance on the part of the user.

The MAINT indicator light goes on at the end of 10,000 hours of use. At that time, be sure to contact your local NBS Service Engineer or call the NBS Service Department (call 1-800-631-5417 toll-free within the USA). This periodic maintenance will keep your unit in premium condition.

### 5.2 Cleaning



#### **CAUTION!**

**The exercise of reasonable care in cleaning the plastic cover will minimize scratching.**

- **Wash the plastic cover with a mild soap or detergent and lukewarm water solution.**
- **Rinse well.**
- **Dry by blotting with a damp cloth or chamois.**

**DO NOT USE window cleaning fluids, scouring compounds, gritty cloths, leaded or ethylene gasolines, or solvents such as alcohol, acetone, carbon tetrachloride, etc.**

The outside painted surfaces can normally be cleaned with a damp cloth and, if necessary, standard household or laboratory cleaners. Do not use abrasive or corrosive compounds to clean this instrument, as they may damage the unit and thereby void the warranty.

To avoid damage to your unit, we recommend the use of NBS door/lid polish (P0860-0949).

**WARNING!**

Before any service or maintenance is performed on the unit, be sure to turn the power OFF using the ON/OFF switch on the front right of the shaker and disconnect the power cord.

### 5.3 Changing Fuses

The unit is designed with a circuit breaker which is used as an ON/OFF switch. There are two fuses on the rear of the unit (*see Figure 2*). One is to protect the control circuitry, and the other is to protect the motor circuit. The motor circuit fuse is mounted in the center of the voltage selector switch.

To remove either fuse:

1. Turn the power off and unplug the power cord.
2. Insert a small flat-bladed screwdriver and turn counter-clockwise until it disengages and the fuse holder springs free.
3. Check the fuse. If it has failed, replace the fuse with a like fuse, as identified in the Spare Parts List. Spare fuses are supplied with the unit.

### 5.4 Changing Voltages

Innova 4000 is set to the appropriate line voltage prior to shipment. The voltage selector switch, however, is a universal power-entry device which can be reset to adapt to worldwide power requirements. The voltage selector switch is located on the rear left of the unit (*see Figure 2*), directly above the power cord connection. If it is necessary to set the unit to a different voltage, use the following procedure:

1. Set the circuit breaker (located on the right side of the unit) to OFF.
2. Disconnect the unit from the power source.
3. Using a small flat-bladed screwdriver, rotate the center portion of the switch until the fuse is disengaged. Remove the fuse.
4. Using a larger flat-bladed screwdriver or a small coin, rotate the center portion of the switch to the desired voltage. The indicator is at the top of the switch.
5. Replace the fuse and holder.
6. Check that the proper power cord is available for the voltage selected.
7. Plug the power cord into the power cord connection on the unit, then plug it into the power source.
8. Set the circuit breaker to the ON position.

The unit is ready for operation.



**WARNING!**

None of the following procedures should be attempted by anyone who is not a service technician authorized by NBS.

### 5.5 Replacing the Belt

1. Turn off the power and unplug the power cord.
2. Lay the unit on its left side, using a soft pad to protect the finish.
3. Remove the bottom cover using a Phillips head (+) screwdriver.

**Figure 7 Belt Replacement & Adjustment**

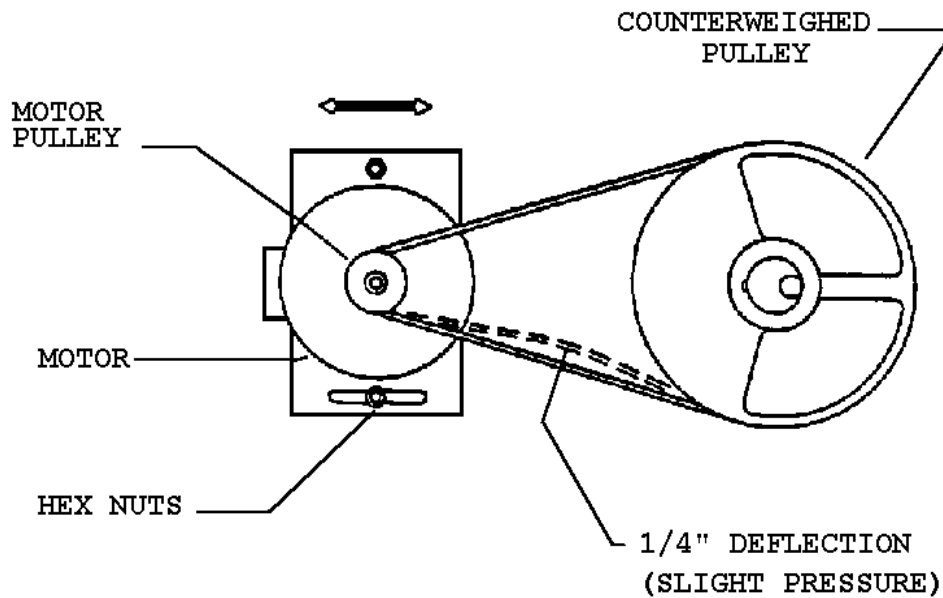

4. Rotate the large pulley (see Figure 7 above) and exert a light pressure to the belt so the belt feeds out of the pulley groove.
5. Install a new belt (NBS part number P0700-5242) by feeding it onto the motor pulley and guiding it onto the large pulley while rotating the large pulley.

**CAUTION!**

Take care to keep fingers clear, to avoid pinching them between the belt and the pulley.

6. Check the belt tension with a light side pressure near the center of the belt. It should deflect approximately 3/8 inch (6.4 mm). If adjustment is needed, loosen the two nuts holding the motor plate and move the plate to either loosen or tighten the belt. Tighten the bolts when the adjustment is correct.
7. Replace the bottom cover.
8. Reconnect the power cord.
9. Set the circuit breaker to the “ON” position. The unit is ready for operation.

## **5.6 Replacing the Motor Assembly**

1. Turn off the power and disconnect the power cord.
2. Lay the unit on its left side using a soft pad to protect the finish.
3. Remove the bottom cover using a Phillips head (+) screwdriver.
4. Remove the connector from the motor (*see Figure 8 below*) by lifting straight up.
5. Remove the 2 hex nuts and washers, then lift out the motor and plate assembly.
6. Separate the motor from the plate by removing the 3 Phillips head screws. Save the hardware.
7. Loosen the pulley set screw and remove the pulley from the shaft. Save the pulley.
8. Mount the new motor (NBS part number M1195-4000) to the motor plate with the 3 Phillips head screws (from step 6).
9. Replace the pulley. Screw the set screw to the shaft flat, but do not tighten it.
10. Position this assembly back onto the unit. Replace the 2 hex nuts and washers. Do not tighten.
11. Replace the belt. Adjust the motor pulley height so that the belt is level as related to the drive pulley. Tighten the set screw.
12. Adjust the belt tension as shown in Figure 7 above. Tighten the 2 hex nuts.
13. Rotate the large pulley by hand and see that the belt tracks smoothly.
14. Replace the motor connector. Be sure the motor connector is positioned (with the pin visible) as shown in Figure 8.
15. Replace the bottom cover.
16. Connect the power cord and turn the circuit breaker to the ON position. The unit is ready for operation.

**Figure 8 Motor Assembly Replacement**

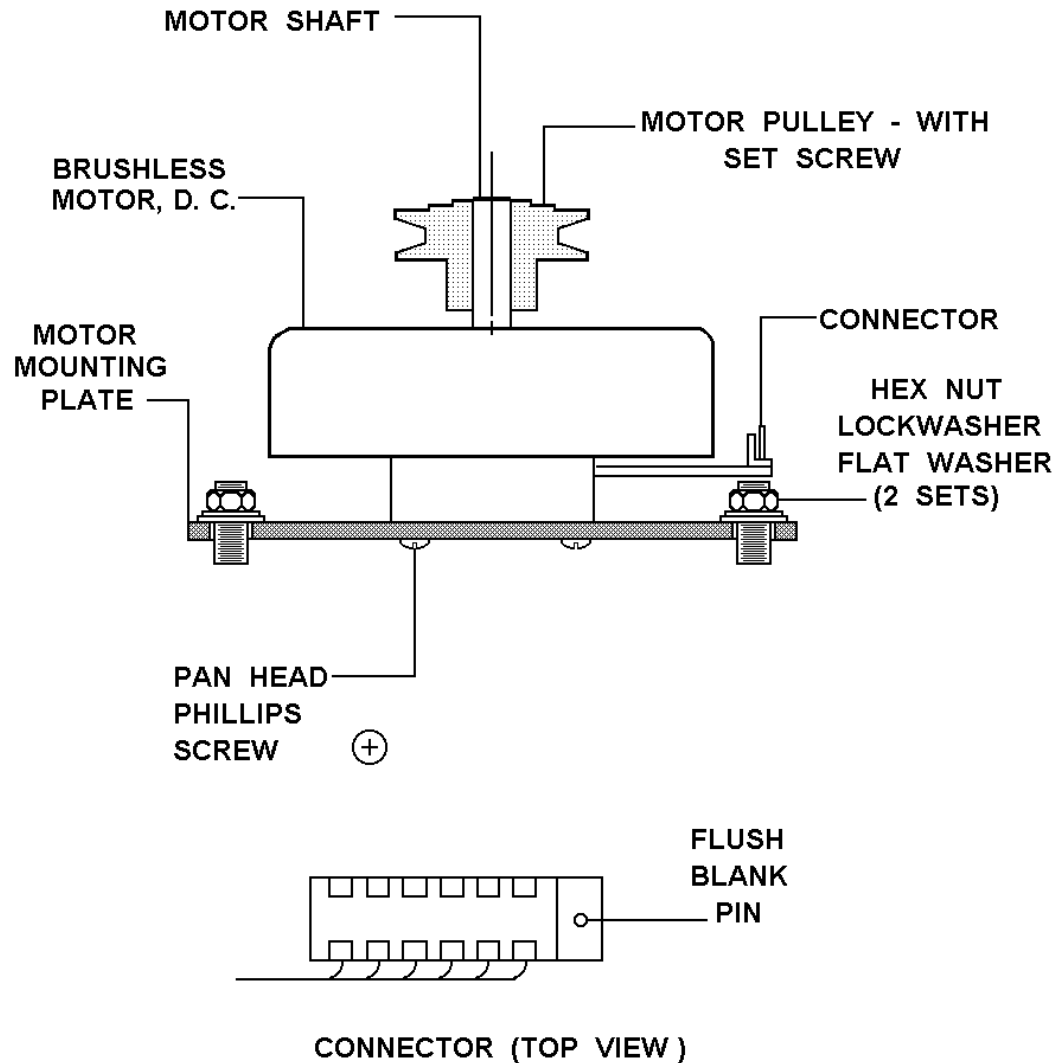

### 5.7 ***MAINT Indicator On***

After the shaker has been operating for 10,000 hours, either initially or since its last service, the MAINT indicator light on the control panel will automatically turn on. This indicates that a routine maintenance check is recommended.

Only an NBS Service Engineer can turn off the MAINT light. A regular schedule of routine maintenance is an excellent way to keep your valuable equipment performing optimally for years of reliable service.

## 5.8 Recorder Adaptation

To record speed and temperature, you can use a recorder (not supplied) that has the following capabilities:

- Two channels, one for speed and one for temperature. Each channel should have signal conditioning which accepts 0-5 volt input.
- A mating connector is required on the recorder cable (not supplied). This is a 9-pin male D subminiature connector: AMP Amplimite HDP-20 series or equivalent.

The pinout diagram (as seen from the back of the unit) and scale below identify the application.

**Figure 9 Recorder Connector**

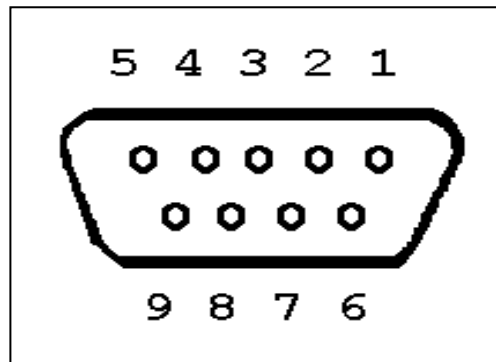

Pin Number	Signal Name	Scale
6	Speed	1V = 100 RPM
2	Ground	
7	Temperature	1V = 20°C
3	Ground	



### **WARNING REMINDER!**

None of the following procedures should be attempted by anyone who is not a service technician authorized by NBS.

## 5.9 Cooling Coil Kit Retrofit Installation

The cooling coil option provides the ability to control below ambient temperatures in the Innova 4000. Control can be maintained at a temperature 5°C or more above the coolant temperature.

The Cooling Coil Kit (NBS part number M1192-9902) should contain the following items:

Qty	Item	Qty	Item
1	cooling coil #M1192-9900	4	screws
4	hose clamps	4	lock washers
2	grommets	4	flat washers
8 feet	reinforced rubber hose	4	nuts

1. Turn the power OFF using the circuit breaker on the right side of unit. Disconnect the power cord.
2. Remove the platform from the unit.
3. Remove the right-hand and left-hand electrical covers (*see Figure 10a*), by removing both screws from each. Save the screws for reuse.

**Figure 10a Cooling Coil Installation**

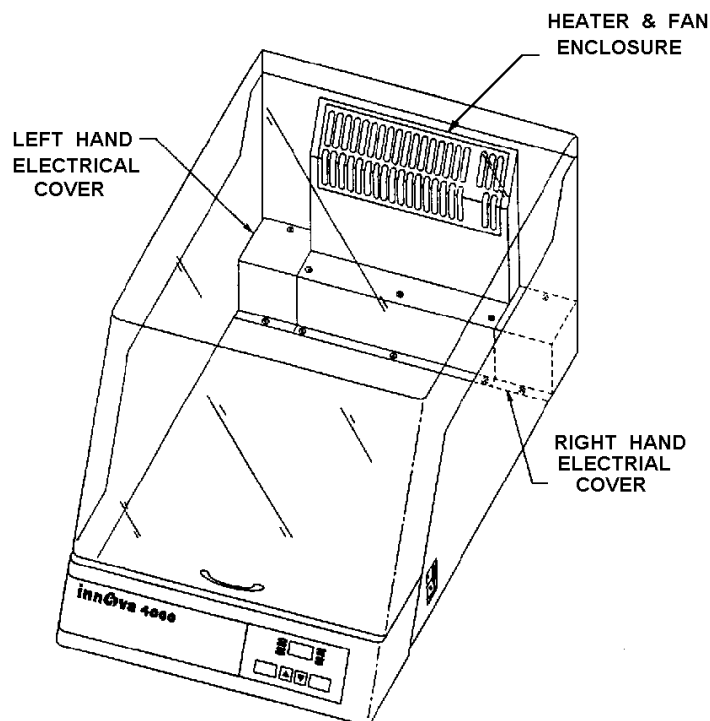

4. Disconnect the three wires (in-line push-on connectors) on the right side of the fan and heater enclosure.
5. Remove the three screws on top of the enclosure to disconnect the fan bracket.
6. Remove the two screws from the flange inside the unit and the two screws from the rear of the unit. Remove the fan and heater enclosure from the unit.
7. Remove the two plugs from the rear lower left side of the unit by prying them out with a flat blade screwdriver. Be careful not to scratch the paint.
8. Install the two grommets supplied in the kit in the two holes where the plugs had been (*see Figure 10b*).

**Figure 10b Cooling Coil Installation**

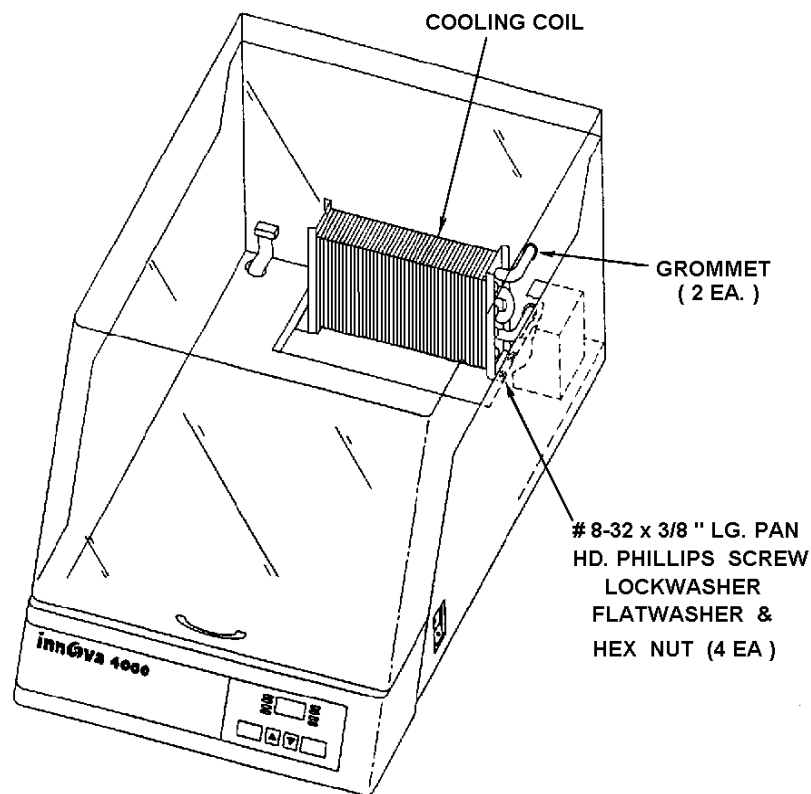

9. Disconnect the red and gray wires from the fan assembly.
10. Lay a soft cloth or cardboard adjacent to the side of the unit. Set the unit on its side, on the cloth or cardboard, taking care to protect the finish of the unit and the plastic hood.
11. Remove the three screws holding the fan bracket assembly (these screws are located on the bottom of the unit).
12. Angle the ends of the coil so they slide through the grommets. Mount the coil to the bottom of the unit using the four screws and hardware provided in the kit. Install from the bottom of unit.

13. Install the fan bracket assembly, using the three screws. Install from the bottom of the unit.
14. Return the unit to its upright position.
15. Connect the **Red** wire to the plus (+) terminal and the **Gray** wire to the negative (-) terminal on the fan assembly.
16. Now, facing the rear of the unit, slip one end of each rubber hose (cut to required lengths, as established by the location of the water supply and the drain) over the coil ends.
17. Slide a hose clamp over each hose and slip each clamp to within 1/8 inch to 3/16 inch from the end of the hose. Tighten the clamps securely and check for leaks.
18. Reassemble unit in reverse order.
19. Attach the two hoses with clamps (supplied) to a coolant supply. One line must go to an open drain or return to a coolant supply, and the other line must be connected to a water supply or a coolant supply.
20. To operate, turn on the cooling supply. Use the control display to set the desired temperature.

If you are using tap water as a coolant, it is preferable that the supply hose be attached to the customer service line with a control valve to minimize water use.



**WARNING!**  
Integrated circuits are extremely susceptible to damage from electrostatic discharge. Read and follow the ESD precautions below.

### **5.10 ESD Precautions**

1. Do not remove components from their antistatic packaging until you are ready to insert them into their sockets or install the board.
2. Before handling components or boards, touch an unpainted portion of the system unit chassis for a few seconds.
3. Wear a wrist grounding strap, available from most electronic components stores.

### **5.11 Replacing the Main Control Board**

1. Switch the shaker OFF and disconnect the power cord.
2. Lay a soft cloth or cardboard out in front of the front panel. Remove the five screws that hold the front panel (two screws on the sides and three screws on the bottom). Allow the front panel to lay on its face, on the cloth or cardboard.

Figure 11 Control Board Replacement

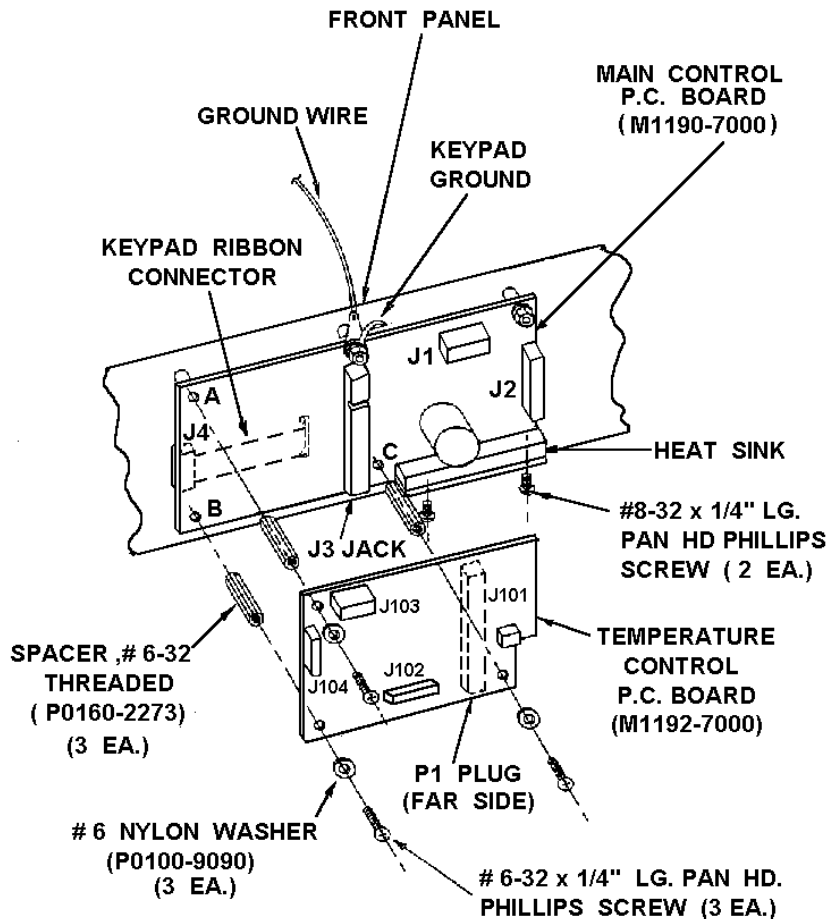

3. Remove the temperature control board (*see Figure 11 above*):
  - a. Disconnect the harness wiring from connectors J101, J102, J103 and J104.
  - b. Remove the three 1/4 inch screws and nylon flat washers.
  - c. Disconnect the temperature control board from the main control board, taking care not to damage the board-to-board connectors. Apply force perpendicular to the plane of the board—do not lift from one end.
4. Disconnect the harness wiring from connectors J1 and J2.
5. Remove the three hex spacers and two 5/16 inch hex nuts.
6. Remove the green wire and the keypad ground lead.
7. Remove the two screws that fasten the heat sink to the front panel bracket.
8. Lift the board out of the front panel and disconnect the keypad connector from J4.

 **NOTE:**

Be careful not to lose the five 1/4 inch spacers or the gray insulator.



9. Position the gray insulator on the solder side of the new main control board (NBS part number M1190-7000). Connect the keypad connector to J4.
10. Make sure the five ¼ inch spacers are in place on the mounting studs, and mount the new main control board.
11. Replace the two screws that fasten the heat sink to the front panel bracket. Do not tighten at this time.
12. Replace the 3 hex spacers, and tighten.
13. Replace the keypad ground lead and the green wire from the main chassis.
14. Replace the two 5/16 inch hex nuts and tighten.
15. Tighten the two heat sink mounting screws.
16. Reconnect the harness wiring to connectors J1 and J2. Make sure that each connector is properly positioned (keys mate and no pins remain exposed).
17. Replace the temperature control board.
18. Replace the front panel, securing it with the five screws.
19. Connect the power cord to the rear of the shaker.

## **5.12 Replacing the Temperature Control Board**

1. Switch the shaker OFF and disconnect the power cord.
2. Lay a soft cloth or cardboard out in front of the front panel.
3. Remove the five screws that hold the front panel (two screws on the sides and three on the bottom). Allow the front panel to lay on its face, on the cloth or cardboard.
4. Disconnect the harness wiring from connectors J101, J102, J103 and J104 (*see Figure 11 above*).
5. Remove the three ¼ inch screws and nylon flat washers.
6. Disconnect the temperature control board from the main control board, taking care not to damage the board-to-board connectors. Apply force perpendicular to the plane of the board—do not lift from one end.
7. Snap the new temperature control board (NBS part number M1192-7000) onto the main control board making sure the board-to-board connectors mate properly.
8. Replace the nylon flat washers and the ¼ inch screws.
9. Reconnect the harness wiring to connectors J101, J102, J103 and J104. Make sure that each connector is properly positioned (keys mate and no pins remain exposed).
10. Replace the front panel, securing it with the five screws.
11. Connect the power cord to the rear of the shaker.

### 5.13 **Installing the Quick Change Platform Option**

The Easy Loading Platform Kit (NBS part number M1192-9901) enables you to change or mount the series of 18 inch x 18 inch (46 cm x 46 cm) platforms without the use of tools or hardware.

The following parts are required to make this upgrade or change. They are included in the kit:

Qty	Item
1	Plastic subplatform with springs, retainers & friction pads attached
1	Counterweight with tapped holes
2	¼ - 20 x 1½ inch long pan head Phillips screws and lock washers
4	¼ - 20 x ¾ inch long Allen socket flat head screws
1	Allen key wrench

#### To install the Quick Change Platform:

1. Turn the power off using the power switch and disconnect the power cord.
2. Check the parts in the kit.
3. Remove the existing platform, if there is one on the machine.
4. Rotate the pulley so that the heavy section is in the extreme right position.
5. Slip the counterweight under the pulley. Mount with the two ¼ inch x 1½ inch long screws and lock washers supplied. Be sure to tighten the screws securely.
6. Mount the subplatform with the 4 flat head Allen screws, keeping the side with the two springs to the front of the machine. Tighten the screws securely.
7. Slip an 18 inch x 18 inch platform between the side guides; push the platform to the rear retainer and press down on the front edge of the platform. It should snap down into place and be retained by the springs. Check that the rear edge of the platform is engaged under the bend of the rear retainer.
8. Plug in the power cord, switch on the power and the unit is ready for operation.

#### To remove the Quick Change Platform:

1. Stop the machine by pressing the START/STOP key.
2. Face the machine squarely.
3. Put your index fingers under each front corner of the platform. Note that there is a relief in these corners on the subplatform. With your thumbs, press the two corner springs toward your body, and with an upward pressure with your index fingers, lift the platform from its retained position.



#### **NOTE:**

**Recommended for speeds up to 400 RPM.**

### 5.14 Gassing Manifold Retrofit Installation

This option provides the ability to bring gas into the chamber via a single input that is distributed through a manifold that provides 5 outlets.

The Gassing Manifold Kit (NBS part number M1036-0291) contains:

Qty	Item	Qty	Item
1	Manifold (M1036-0281)	2	Screws 8-32 x 5/8 inch long, pan head, stainless steel
1	Grommet		
2	Clips	6 feet	Tubing
2	Spacers	1	Clamp

1. Turn off the power to the unit.
2. Pry out the three plastic plug buttons on the right side of the unit. Use a small flat blade screwdriver. Do not mar the paint finish.
3. Use a sharp tool to pierce through the insulation under the three exposed holes.

**Figure 12 Gassing Manifold Kit Installation (Top View)**

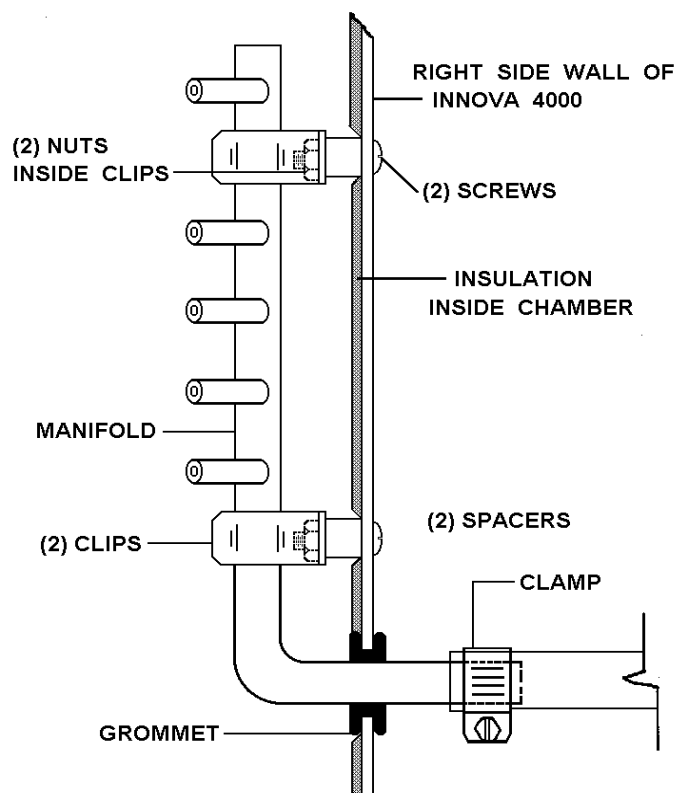

4. Snap the grommet into the large hole (*see Figure 12*).
5. Insert the two screws through the holes, add the two clips and the two nuts to retain the clips. Position the two clips so that the manifold pipe will be held horizontally, and tighten the two nuts.
6. Push the large pipe section of the manifold through the grommet from the inside of the chamber.
7. Snap the manifold pipe into place so that it is retained by the two clips. The five outlets will be facing upward at a 60° (approximately) angle.
8. Using the clamp, attach the tubing externally to the manifold. Cut the tubing to a length to suit and attach the other end of the tubing to the gas supply. Internal tubing, caps, etc. are to be supplied by the Customer as required.

## 6 APPENDIX

*This section contains additional information of interest, but not essential to the operation or care of your Innova shaker.*

### 6.1 Specifications

<b>SHAKING</b>	
<b>Speed</b>	25-500 RPM
<b>Motion</b>	¾ inch (19 mm) diameter circular orbit
<b>Indication</b>	LED digital electric display, 1 RPM increments
<b>Setpoint &amp; Control</b>	Digital adjustment with PI microprocessor control and instantaneous visual feedback
<b>Accuracy</b>	± 1 RPM
<b>DRIVE</b>	
Triple eccentric counterbalanced ball bearing drive	
<b>TEMPERATURE</b>	
<b>Range</b>	5°C above ambient to 60.0°C (Innova 4000) 5°C above ambient to 80.0°C (Innova 4080)
<b>Range with Cooling</b>	5°C above coolant using cooling coil accessory (option)
<b>Control Stability</b>	± 0.1°C by use of PI microprocessor controller and pulse width modulation of heater
<b>Setpoint</b>	Digital adjustment increments within 0.1°C instantaneous visual feedback
<b>Accuracy</b>	± 0.1° @ 30-40°C range
<b>Uniformity</b>	± 0.5° for remaining range
<b>Safety</b>	Better than 0.5°C Heater shuts off if temperature exceeds operating range
<b>Heater</b>	Low watt density resistance heater with high temperature safety thermostat
<b>TIMER</b>	
<ul style="list-style-type: none"> <li>• Programmable shaking periods from 0.1 to 99.9 hours by a digital timer that shuts off at the end of period and energizes status light.</li> <li>• Timer counts down and digital display indicates remaining time.</li> <li>• Can be deactivated for continuous operation.</li> <li>• Additionally, unit will display total accumulated running time for service information.</li> </ul>	
<b>OPERATING AMBIENT ENVIRONMENT</b>	
0° - 40°C, 90% humidity, non-condensing.	

<b>SELF-DIAGNOSTIC STATUS</b>	
Warning signal (audible and visible) indicates when shaking speed deviates more than 5 RPM or the temperature deviates more than 1.0°C from set point and when timer operation has expired. Audible alarm can be deactivated/activated by the operator.	
<b>REMOTE MONITORING</b>	
Chart recorder outputs for speed and temperature (0-5V). 1V per 100 RPM; 1V per 20°C, accuracy $\pm 25$ mV.	
<b>AUTOMATIC RESTART</b>	
Unit will automatically restart after undesired power interruption. Setpoints are maintained by non-volatile memory. Interruption is indicated by a flashing display.	
<b>MOTOR</b>	
1/15 HP, 3 phase brushless ball bearing DC motor.	
<b>ELECTRICAL SERVICE</b>	
<b>Voltage</b>	<ul style="list-style-type: none"> <li>• 100V, 50/60 Hz</li> <li>• 120V, 50/60 Hz</li> <li>• 220V, 50/60 Hz</li> <li>• 240V, 50/60 Hz</li> </ul>
<b>VA Requirements</b>	600 VA for Innova 4000 900 VA for Innova 4080
Universal power entry system adapts to US or International requirements.	
<b>DIMENSIONS</b>	
<b>Width</b>	21 inches (53.4 cm)
<b>Depth</b>	27½ inches (69.9 cm)
<b>Height</b>	19¾ inches (50 cm)
<b>CONSTRUCTION</b>	
Heavy gauge steel, phosphate-coated and texture painted cabinet. See-through plastic cover.	
<b>WEIGHT</b>	
<b>Net</b>	150 lbs (68 kg)
<b>Gross</b>	200 lbs (91 kg)
<b>PLATFORM DIMENSIONS</b>	
18 inches X 18 inches (46 cm x 46 cm), Phenolic composite.	
<b>CHAMBER DIMENSIONS (interior)</b>	
<b>Width</b>	19¾ inches (50.2 cm)
<b>Depth</b>	19 inches (48.3 cm)
<b>Height</b>	13¼ inches (33.6 cm) above the platform

## 6.2 Available Platforms

### 6.2.1 Easy Load Platform Option

Quick-change platform option is available. This easy-load accessory enables the user to snap-in platforms without tools or hardware.

The kit (M1192-9901) includes a sub-platform with spring clips, and extra counterweight and hardware. The kit does not include a platform. Once installed, a speed of 25-400 rpm is recommended.

The package should be installed by a qualified Service Engineer.

### 6.2.2 Interchangeable Platforms

The following platforms, test tube racks and related accessories are available:

Catalog No.	18 in. X 18 in. (46 cm X 46 cm) Platform Size*	
	Clamps	Size of Glassware
M1194-9901	XX	Universal Platform**
M1194-9903	64	50 ml Erlenmeyer Flask
M1194-9904	34	125 ml Erlenmeyer Flask
M1194-9905	25	250/300 ml Erlenmeyer Flask
M1194-9906	16	500 ml Erlenmeyer Flask
M1194-9907	9	1L Erlenmeyer Flask
M1194-9908	5	2L Erlenmeyer Flask
M1194-9909	XX	Utility Carrier
M1194-9910	XX	Utility Tray

\*All above platforms constructed of phenolic composite

\*\*Flask clamps must be ordered separately

Catalog Number	Tubes per Rack	Test Tube Racks (must be used on the Universal Platform M1194-9900)	Racks per Platform
TTR-111	48	Rack for 13 mm Tubes	3
TTR-121	33	Rack for 20 mm Tubes	3
TTR-122	21	Rack for 25 mm Tubes	3
TTR-199	15	Adjustable Angle Slant Rack	2
TTR-208	15	Rack for 30 mm Tubes*	3

\* used for 50 ml centrifuge tubes

### 6.3 Service Parts List

<b>NBS Part Number</b>	<b>Description</b>	<b>Quantity</b>
P0380-3710	0.16 Amp Fuse (Low Voltage)	1
P0380-3532	1.6 Amp Fuse (Selector Switch)	1
P0420-1610	10 VA Transformer	1
M1191-5300	130 VA Transformer	1
P0320-0350	21000 uF Capacitor	1
P0460-4091	Diode Bridge	1
P0360-4040	130V Varistor	2
M1195-4001	Medium Motor Assembly	1
M1190-9940	Main Control Board	1
M1192-7000	Temperature Control Board	1
M1190-5000	Membrane Switch Panel	1
P0400-0980	Voltage Selector Switch	1
P0400-4330	10 Amp Circuit Breaker	1
P0400-3011	10 Amp Solid State Relay	1
P0400-2751	Relay	1
P0620-1381	500 Watt Heater (Innova 4000)	1
P0620-1382	750 Watt Heater (Innova 4080)	1
M1195-8001	RTD Assembly	1
P0720-2024	Power Cord 120V 15 Amp	1
P0720-2021	Power Cord 220V	1
P0180-0102	Bearing Sealed Upper Housing	3
P0180-0101	Bearings Shielded (lower hsg.)	6
P0700-5242	Belt	1
M1233-6331	Bearing Housing Assembly	1
M1192-9409	Lid Gasket	1
P0400-1531	Magnetic Switch	1
P0400-1538	Magnet	1
P0620-2538	4-inch Fan	1
M1192-9914	Replacement Cover Assembly	1
P0860-0949	Door/Lid Polishing Kit	1



## 6.4 Accessories

### 6.4.1 Retrofit Option Kits

Catalog No.	Description
M1192-9902	Cooling Coil Kit*
M1036-0291	Gassing Manifold Kit

\* For below ambient temperatures. Permits temperature control to 5°C above coolant temperature. Can be field installed by an **NBS-qualified Service Technician**.

### 6.4.2 Accessory Flask Clamps

Catalog No.	Description
ACE-10S	10 ml Erlenmeyer Clamp
ACE-25S	25 ml Erlenmeyer Clamp
ACE-50S	50 ml Erlenmeyer Clamp
ACE-125S	125 ml Erlenmeyer Clamp
ACE-250S	250 ml Erlenmeyer Clamp
ACE-500S	500 ml Erlenmeyer Clamp
ACE-1000S	1.0L Erlenmeyer Clamp
ACE-2000S	2.0L Erlenmeyer Clamp
ACE-4000S	4.0L Erlenmeyer Clamp
ACE-6000S	6.0L Erlenmeyer Clamp
ACE-2800S	2800 ml Fernbach Flask Clamp
ACSB-500S	500 ml Media Bottle Clamp
ACSB-1000S	1.0L Media Bottle Clamp

All of the clamps listed above are constructed of stainless steel.

### 6.4.3 Clamp Mounting Hardware Kits

NBS Flask Clamps are used on a variety of shaker platforms. Flat head screws of different lengths and thread pitch are used to secure the clamps.

*See the tables in Section 3.7* to identify the proper screws for your shaker application by reference to the head style.

**THIS PAGE INTENTIONALLY BLANK**

# 7 DRAWINGS

## 7.1 Control Schematic

Figure 13: Control Schematic, Overview

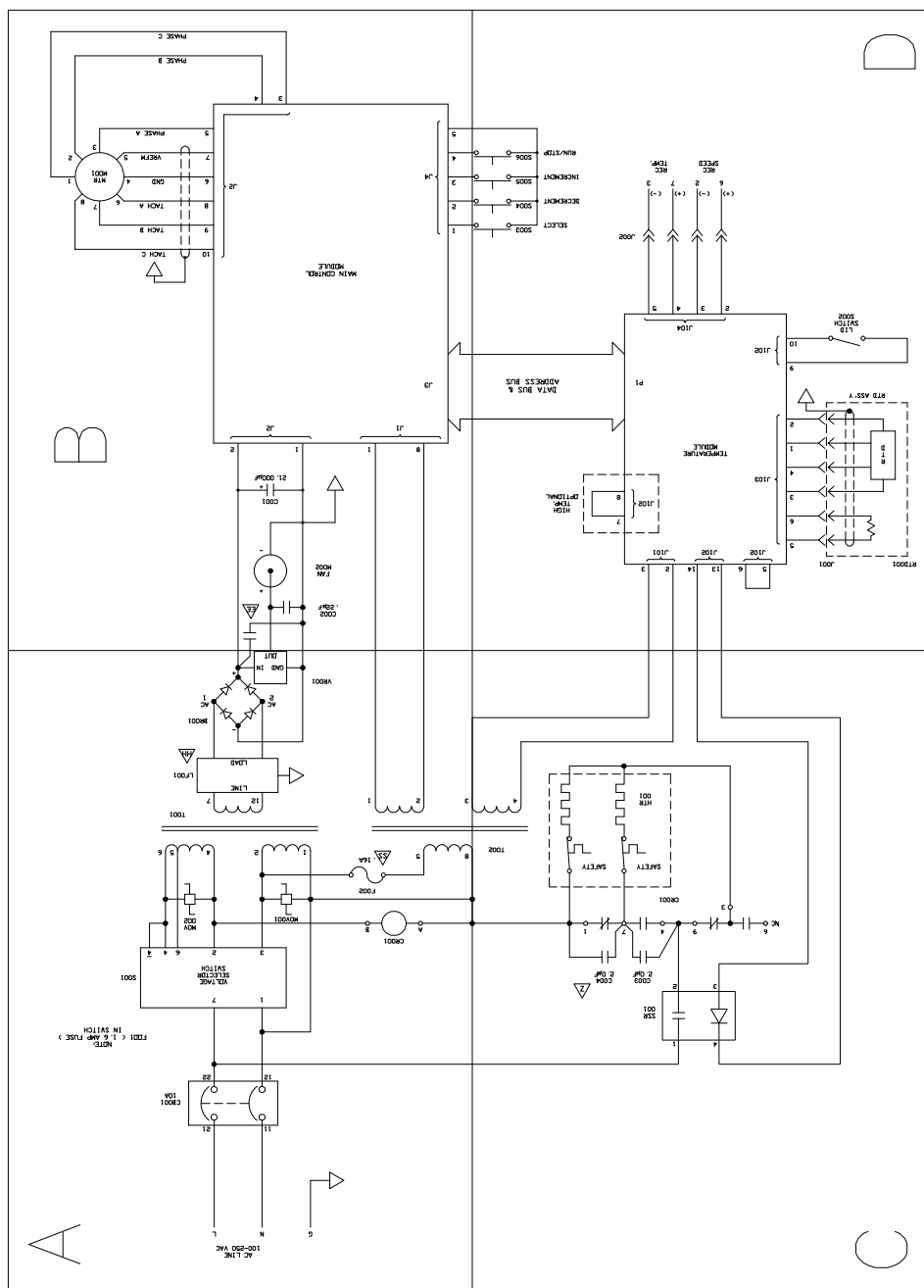

Figure 14: Control Schematic, Quadrant A

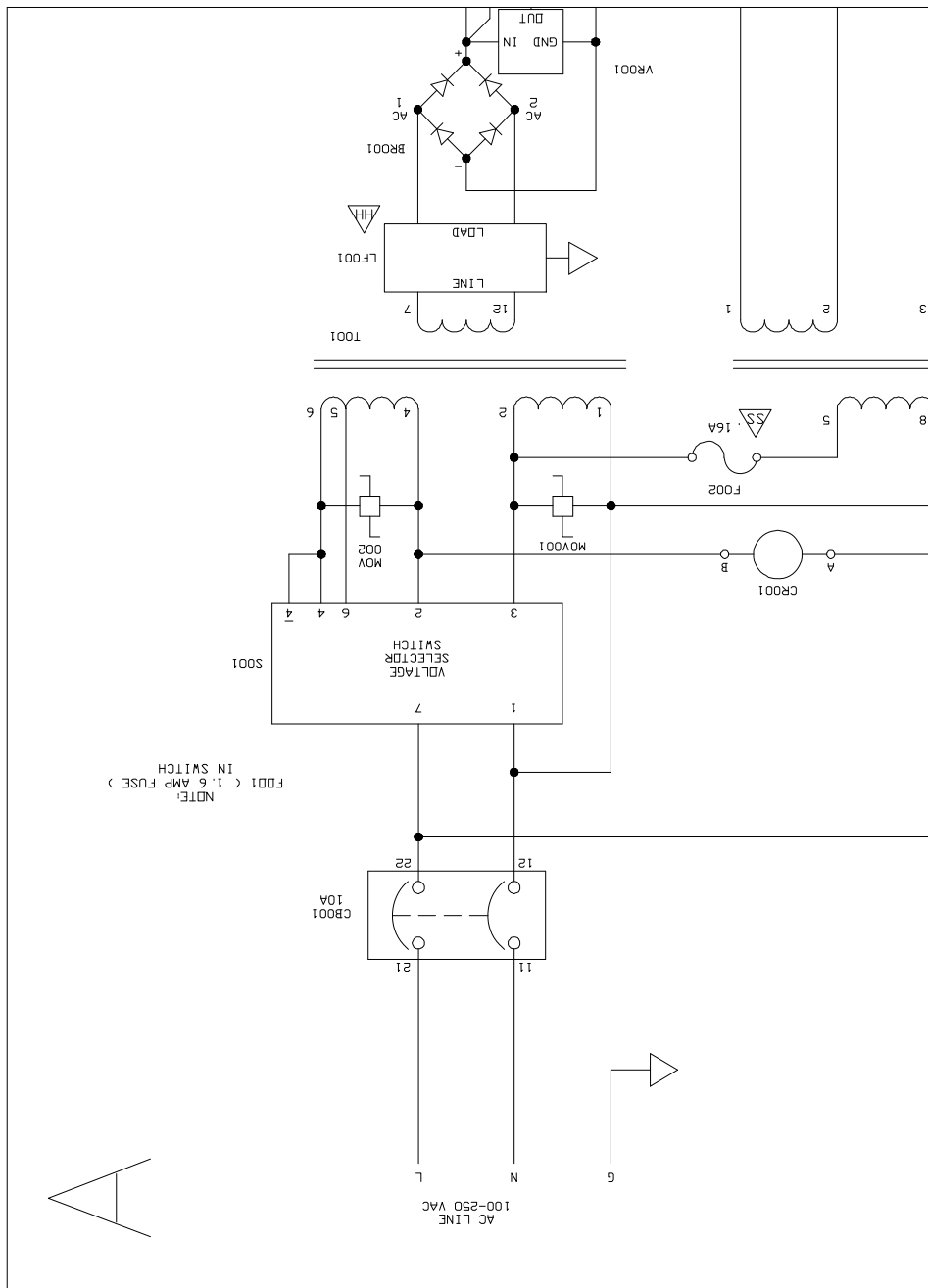

Figure 15: Control Schematic, Quadrant B

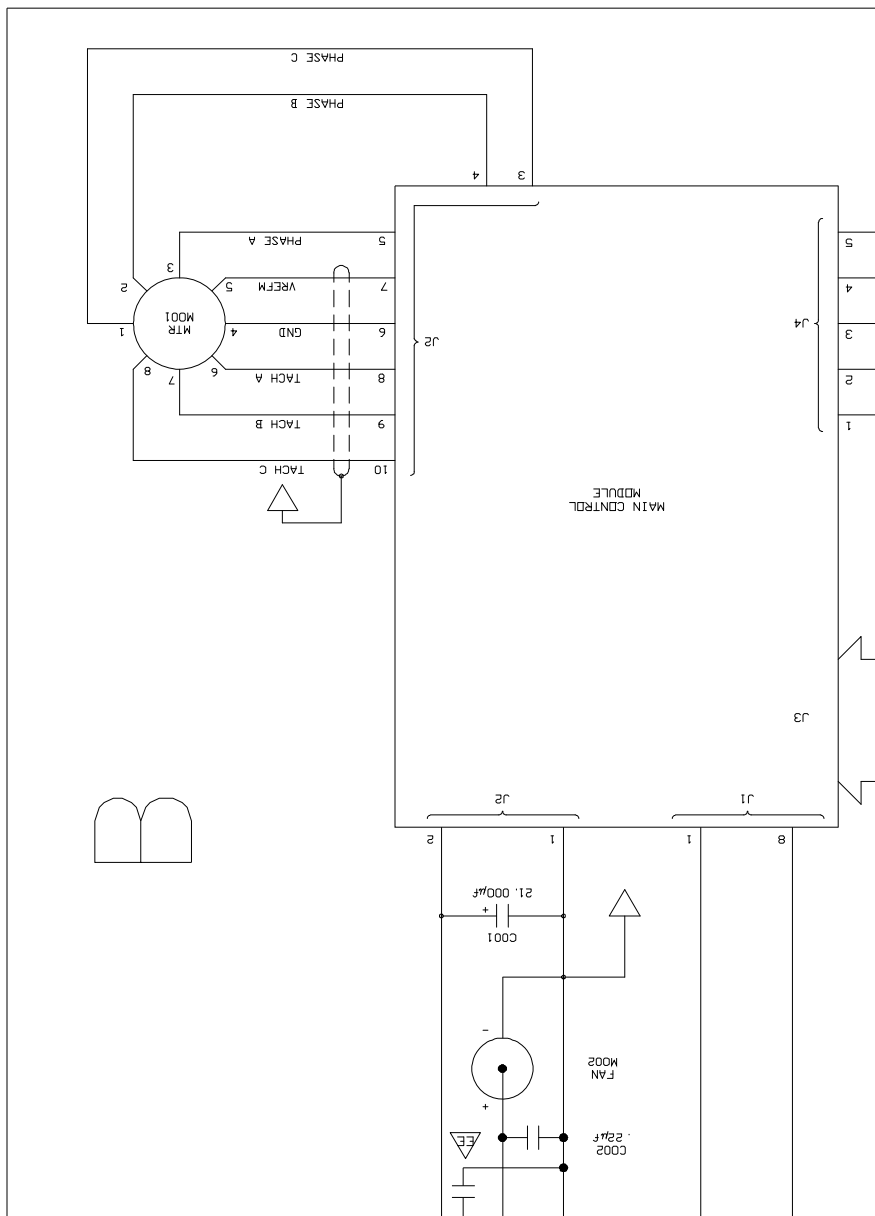

Figure 16: Control Schematic, Quadrant C

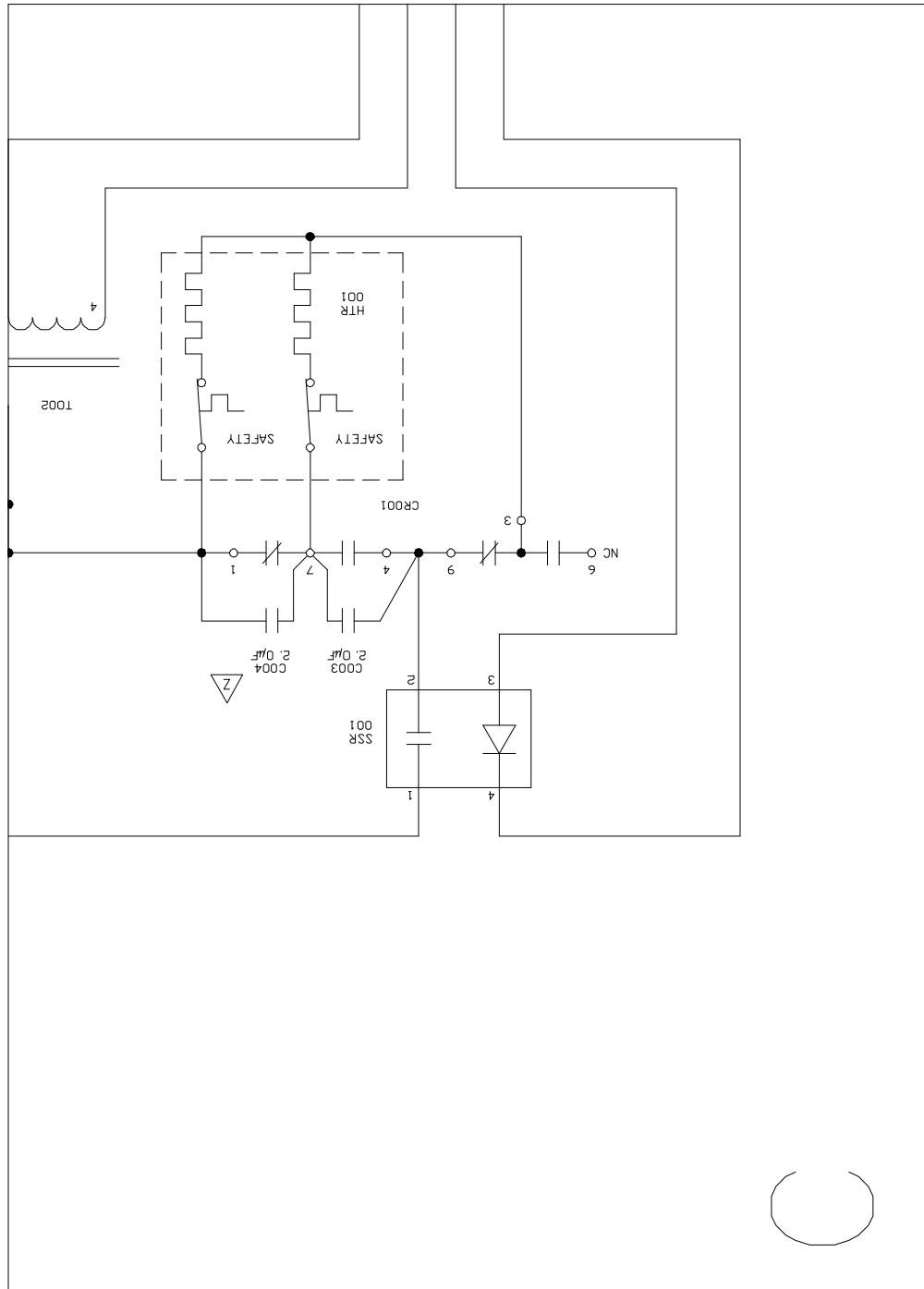
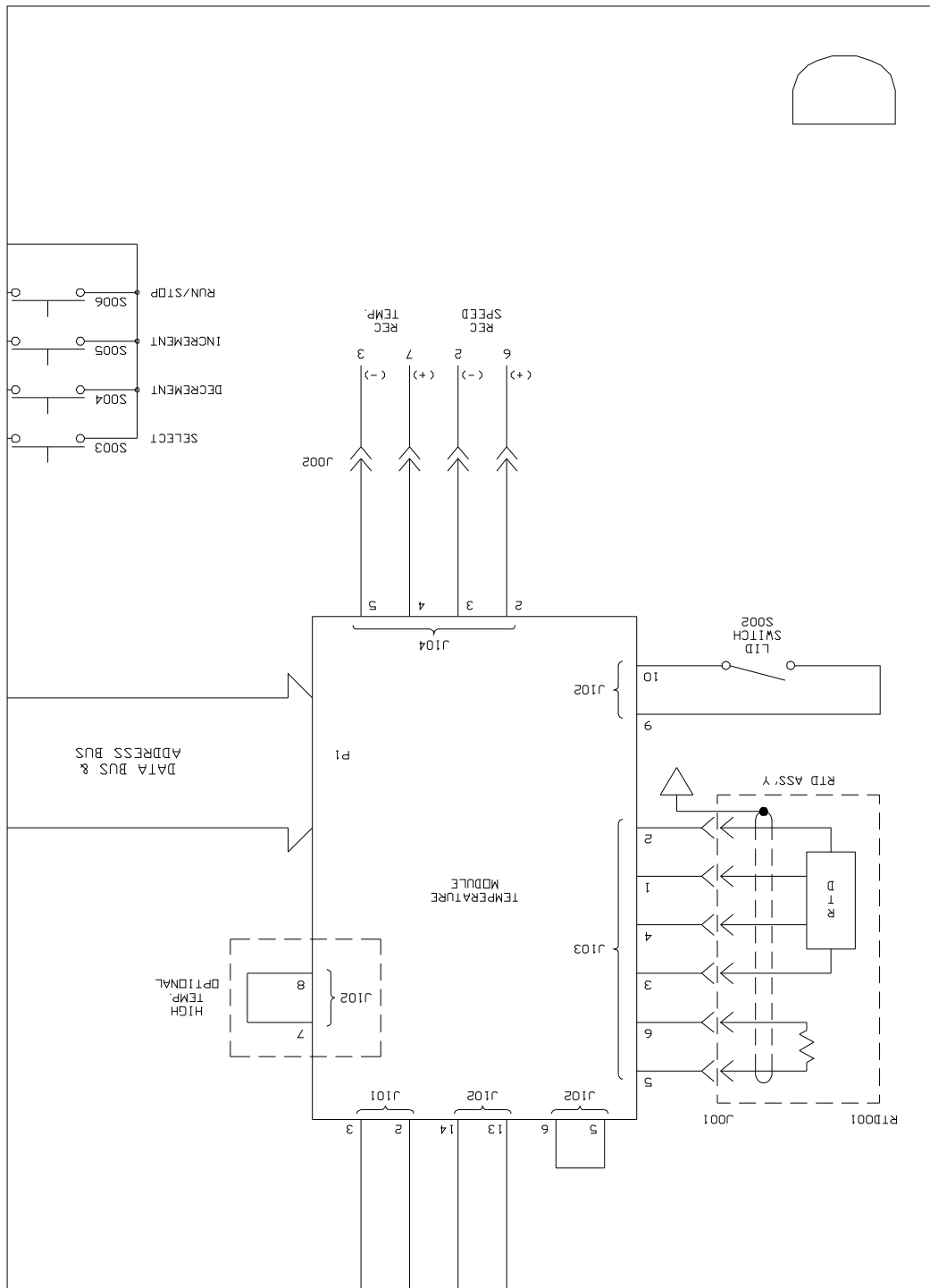

Figure 17: Control Schematic, Quadrant D



## 7.2 *List of Illustrations*

<b>Figure No.</b>	<b>Description</b>	<b>Page</b>
1	Front View of Shaker	4
2	Rear View of Shaker	5
3	Control Panel	6
4	Counterbalanced Drive Mechanism	9
5	Space Requirements	13
6	2- to 6-Liter Flask Clamp Installation	15
7	Belt Replacement & Adjustment	25
8	Motor Assembly Replacement	27
9	Recorder Connector	28
10a	Cooling Coil Installation	29
10b	Cooling Coil Installation	30
11	Control Board Replacement	32
12	Gassing Manifold Kit Installation	35
13-17	Control Schematic	43-47



# 8 INDEX

o  
 °C Function Indicator Light, 19  
 °C Indicator Light, 8  
   Pulsing of, 20

## 2

2800 ml Fernbach Flask Clamps, 16

## 4

4080  
   Unique features of, 1, 3, 19, 37, 38

## A

Accessories, 41  
 Accessory Flask Clamps, 41  
 Accumulated Running Time, 21  
 Actual Temperature, 20  
 Alarm  
   Deactivating the, 19  
   Reactivating the, 19  
   Stopping the, 18  
 Automatic Restart, 38

## B

Bearings, 10  
 Belt Tension  
   Adjusting the, 26  
   Checking the, 26

## C

Cancelling the Timer, 18  
 CAUTION  
   Symbol for, vii  
 Chamber Dimensions, 38  
 Changing Fuses, 24  
 Changing Setpoints, 17, 18  
 Changing Voltage, 24  
 Chart Recorder, 19, 28  
 Chart Recorder Connector  
   Location of, 5  
 Checking Setpoints, 18  
 Clamp Mounting Hardware, 41  
 Cleaning, 23  
   Products to avoid for, 23  
   Products to use for, 23  
 Construction, 38  
 Construction Features, 9

Continuous Run, 17  
 Control Panel, 6, 7  
 Control Schematic, 43  
 Cooling Coil (optional)  
   Location of, 5  
 Cooling Coil Kit, 29, 41  
 Cooling Coil Option, 8  
   Installing the, 29  
 Copyright Notice, vii

## D

Damage, 11  
 Dimensions, 38  
   Chamber, 38  
   Platform, 38  
   Shaker, 38  
 Disclaimer Notice, vii  
 Drawings  
   Index of, 48  
 Drive, 37  
 Drive Belt  
   Adjusting the, 25  
   Replacing the, 25  
 Drive Mechanism, 9

## E

Easy Load Platform Option, 39  
 Easy Loading Platform Kit, 34  
 Electrical Connections, 14  
 Electrical Service, 11, 14, 38  
 Electronic Boards, 10  
 ESD Precautions, 31

## F

Flask Clamp Hardware Tables, 16  
 Flask Clamp Installation, 15  
 Flask Clamp Mounting Hardware, 41  
 Flask Clamps, 41  
 Front View, 3  
 Function Indicator Lights, 6, 8  
 Fuses  
   Changing the, 24  
   Location of, 5

## G

Gassing Manifold Kit, 35, 41  
 Gassing Manifold Option, 8  
   Installing the, 35

- H**
- Hose Connections, 12
  - HOURS Indicator Light, 8
  - HRS Display
    - Interpreting the, 21
- I**
- Indicated Temperature, 20
  - Inspection, 11
  - Installation Space, 12, 13
  - Interchangeable Platforms, 39
  - International Offices
    - List of, iii
- L**
- LED Display, 6, 17
  - LID Display, 6, 17
- M**
- Main Control Board, 10
    - Replacing the, 31
  - MAINT Indicator Light, 7, 21, 23, 27
  - Maintenance, 23
  - Manual Conventions, vii
  - Motor, 10, 26, 38
  - Motor Assembly
    - Replacing the, 26, 27
  - MUTE Indicator Light, 7, 19
- N**
- NOTE
    - Symbol for, vii
- O**
- On/Off, 17
  - Operating Ambient Environment, 37
  - Options Available, 8
- P**
- Platform Accessories, 39
  - Platform Assemblies, 8
  - Platform Dimensions, 38
  - Platform Installation, 14
  - Platforms Available, 39
  - Power Cord Connection
    - Location of, 5
  - Programmed Functions, 18
- Q**
- Quick Change Platform Option, 8, 14, 39
    - Installing the, 34
    - Removing the, 34
- R**
- Speed limitation for, 34
  - Rear View, 5
  - Recorder Adaptation, 28
  - Recorder Channels, 28
  - Recorder Connector, 28
  - Recorder Pinout Diagram, 28
  - Recording Speed, 28
  - Recording Temperature, 28
  - Remote Monitoring, 38
  - Retrofit Option Kits, 41
  - Retrofit Options Available, 8
  - Routine Maintenance, 23
  - RPM Indicator Light, 8, 17
  - Running Time
    - Displaying the, 21
- S**
- Safety Switch, 3
  - SELECT Key, 6, 7, 17
  - Self-Diagnostic Status, 38
  - Service Parts, 39
  - SET Indicator Light, 7, 17
  - SET Mode, 17
  - Set Speed, 17
  - Setting the Timer, 18
  - Shaking, 37
    - Starting the, 17
    - Stopping the, 17
  - Space Requirements, 12, 13
  - Specifications, 37
  - Speed Setpoint, 17
  - START/STOP Key, 6, 7
  - Starting the Shaker, 19
  - Starting the unit, 17
  - Status Indicator Lights, 6, 7
  - Stopping the Shaker, 19
- T**
- Table of Contents, xi
  - Temperature, 37
  - Temperature Alarm
    - Activating the, 19
    - Audible, 19
    - Visible, 19
  - Temperature Control, 19
  - Temperature Control Board, 10
    - Removing the, 32
    - Replacing the, 33
  - Temperature Correction Value, 20
  - Temperature Offset Calibration, 20
  - Temperature Range, 19
  - Temperature Setpoint
    - Setting the, 19
  - Test Tube Racks, 39
  - TIME Indicator Light, 7

Timed Functions, 18  
Timer, 37  
Total Running Time, 21  
Triple Eccentric Drive, 9

**U**

Universal Power, 5  
Unlimited Run, 17  
Unpacking, 11

**V**

Vent, 21

Location of, 5  
Voltage Configuration, 11  
Voltage Selection, 5, 11, 24  
Voltage Selection Switch  
Location of, 5

**W**

WARNING  
Symbol for, vii  
Warranty, ix  
Weight, 38

