



Leica RM2235

Rotary Microtome

CE

Instruction Manual

Leica RM2235

V1.4; Rev B, English – 02/2010

Always keep this manual with the instrument.

Read carefully before working with the instrument.

Leica
MICROSYSTEMS

NOTE

The information, numerical data, notes and value judgments contained in this manual represent the current state of scientific knowledge and state-of-the-art technology as we understand it following thorough investigation in this field.

We are under no obligation to update the present manual periodically and on an ongoing basis according to the latest technical developments, nor to provide our customers with additional copies, updates etc. of this manual.

For erroneous statements, drawings, technical illustrations etc. contained in this manual we exclude liability as far as permissible according to the national legal system applicable in each individual case.

In particular, no liability whatsoever is accepted for any financial loss or consequential damage caused by or related to compliance with statements or other information in this manual.

Statements, drawings, illustrations and other information as regards contents or technical details of the present manual are not to be considered as warranted characteristics of our products.

These are determined only by the contract provisions agreed between ourselves and our customers.

Leica reserves the right to change technical specifications as well as manufacturing processes without prior notice. Only in this way is it possible continuously to improve the technology and manufacturing techniques used in our products.

This document is protected under copyright laws. Any copyrights of this document are retained by Leica Biosystems Nussloch GmbH.

Any reproduction of text and illustrations (or of any parts thereof) by means of print, photocopy, microfiche, web cam or other methods – including any electronic systems and media – requires express prior permission in writing by Leica Biosystems Nussloch GmbH.

For the instrument serial number and year of manufacture, please refer to the name plate at the back of the instrument.

© Leica Biosystems Nussloch GmbH

Published by:

Leica Biosystems Nussloch GmbH

Heidelberger Str. 17 - 19

D-69226 Nussloch

Germany

Phone: +49 (0) 6224 143-0

Fax: +49 (0) 6224 143-268

Internet: <http://www.leica-microsystems.com>

Table of contents

1.	Important notes	6
2.	Safety	7
	2.1 Safety notes	7
	2.2 Warnings	7
	2.3 Integrated safety devices	10
3.	Instrument components and specifications	12
	3.1 Overview – instrument components	12
	3.2 Instrument specifications	13
	3.3 Technical data	14
4.	Startup	15
	4.1 Standard delivery	15
	4.2 Installation site requirements	15
	4.3 Unpacking and installation	16
	4.4 Assembling the handwheel	18
	4.5 Inserting the universal cassette clamp	19
	4.6 Inserting the knife holder	20
5.	Operation	21
	5.1 Operating elements and their functions	21
	5.1.1 Section thickness setting	21
	5.1.2 Coarse driving wheel	21
	5.1.4 Mechanical trimming function	22
	5.1.3 Specimen retraction	22
	5.1.5 Specimen holder with precision orientation	23
	5.2 Adjusting the clearance angle	24
	5.3 Fine adjustment of the force balance	25
	5.4 Clamping the specimen	26
	5.5 Clamping the knife / disposable blade	26
	5.6 Sectioning	27
	5.7 Changing the specimen or interrupting sectioning	28
	5.8 Finishing daily routine	28
6.	Optional accessories	29
	6.1 Assembly for fixture for specimen clamps	29
	6.1.1 Rigid fixture for specimen clamps	29
	6.1.2 Directional fixture for specimen clamps	29
	6.1.3 Fine-directional fixture for specimen clamps	30

6.1.4	Quick clamping system	31
6.2	Specimen clamps and holders	32
6.2.1	Standard specimen clamp	32
6.2.2	Vee insert	32
6.2.3	Foil clamp type 1	33
6.2.4	Foil clamp type 2	34
6.2.5	Universal cassette clamp	35
	Universal cassette clamp, ice-cooled	35
6.2.6	Super mega-cassette clamp	36
6.2.7	Holder for round specimens	37
6.3	Knife holder base and knife holder	38
6.3.1	Knife holder base, without lateral movement feature	38
6.3.2	Knife holder E/E-TC	39
6.3.3	Knife holder N/NZ	42
6.4	Section waste tray	44
6.5	Backlighting	44
6.6	Tray	45
6.7	Freezer pack	45
6.8	Universal microscope carrier	46
6.9	Magnifying lens	48
6.10	Ordering information	49
7.	Customized solutions	51
7.1	Possible faults	51
7.2	Instrument malfunctions	51
8.	Cleaning and maintenance	52
8.1	Cleaning the instrument	52
8.2	Maintenance instructions	54
8.3	Lubricating the instrument	55
9.	Warranty and service	56

1. Important notes

Symbols in the text and their meanings



Dangers, warnings and cautions appear in a gray box and are marked by a warning triangle .



Notes, i.e. important user information appear in a gray box and are marked by an information symbol .

(5)

Numbers in parentheses refer to item numbers in illustrations.

Qualification of personnel

- The Leica RM2235 may be operated by trained laboratory personnel only.
- All laboratory personnel designated to operate the Leica instrument must read this instruction manual carefully and must be familiar with all technical features of the instrument before attempting to operate it.

Intended use of instrument

The Leica RM2235 is a manually operated rotation microtome for creating thin sections of specimens of varying hardness for use in routine and research laboratories in the fields of biology, medicine and industry.

It is designed for sectioning soft paraffin specimens as well as harder specimens, as long as they are suitable for being cut manually.

Any other use of the instrument is considered improper!

Instrument type

All information provided in this manual applies only to the instrument type indicated on the cover page.

An identification label indicating the instrument serial number is attached at the left side of the instrument.



Fig. 1



Be sure to comply with the safety instructions and warnings provided in this chapter. Be sure to read these instructions, even if you are already familiar with the operation and use of other Leica products.

2.1 Safety notes

This instruction manual contains important instructions and information regarding the operational safety and maintenance of the instrument.

The instruction manual is an important part of the product, which must be read carefully prior to startup and use and must always be kept near the instrument.



If additional requirements on accident prevention and environmental protection exist in the country of operation, this instruction manual must be supplemented by appropriate instructions to ensure compliance with such requirements.

This instrument is built and inspected according to the Safety requirements for laboratory instruments.

For current information about applicable standards, please refer to the CE declaration of conformity on our Internet site:

www.leica-microsystems.com

In order to maintain this condition and ensure safe operation, the operator must observe all the instructions and warnings contained in this instruction manual.



The protective devices on both instrument and accessories may neither be removed nor modified. Only service personnel qualified by Leica may repair the instrument and access the instrument's internal components.

2.2 Warnings

The safety devices installed in this instrument by the manufacturer only constitute the basis for accident prevention. Primarily responsible for accident-free operation is above all the owner of the instrument and, in addition, the designated personnel who operates, services or cleans the instrument.

To ensure trouble-free operation of the instrument, make sure to comply with the following instructions and warnings.

2. Safety

Warnings – Safety instructions / warning labels attached to the instrument



- Safety instruction labels on the instrument marked with a warning triangle indicate that the correct operating instructions (as described in this manual) must be followed when operating or replacing the instrument component bearing the label.

Failure to adhere to these instructions may result in an accident, personal injury, damage to the instrument or accessory equipment.

Warnings – Transport and installation



- Once removed from the crate, the instrument may only be transported in an upright position.
- Do not transport the instrument by holding it by the handwheel grips, coarse driving wheel or the knob for setting the section thickness.
- The protective devices on both instrument and accessories must neither be removed nor modified.

Warnings – Working at the instrument



- Take care when handling microtome knives and disposable blades. The cutting edge is extremely sharp and can cause severe injury!
- Always remove the knife / blade before detaching the knife holder from the instrument. Always put the knives back into the knife case when not in use!
- Never place a knife anywhere with the cutting edge facing upwards and never try to catch a falling knife!
- Always clamp the specimen block BEFORE clamping the knife.

Warnings – Working at the instrument



- **Prior to manipulating the knife and specimen, or changing the specimen or knife, and during breaks, always lock the handwheel and cover the cutting edge with the knife guard!**
- **ALWAYS turn the handwheel clockwise; otherwise, the brake will not work properly.**
- **Always wear protective glasses when sectioning brittle specimens. Specimen may splinter!**
- **Specimen blocks must not be oriented during the retraction phase! If a block is oriented during retraction, the block will advance by the retraction value PLUS the selected section thickness before the next section. This may cause damage to both specimen and knife!**

Warnings – Cleaning and maintenance



- **Always lock the handwheel before cleaning!**
- **Do not use any solvents containing acetone or xylene for cleaning!**
- **Ensure that no liquids enter the interior of the instrument when cleaning!**
- **When using detergents please comply with the safety precautions of the manufacturer.**

2. Safety

2.3 Integrated safety devices

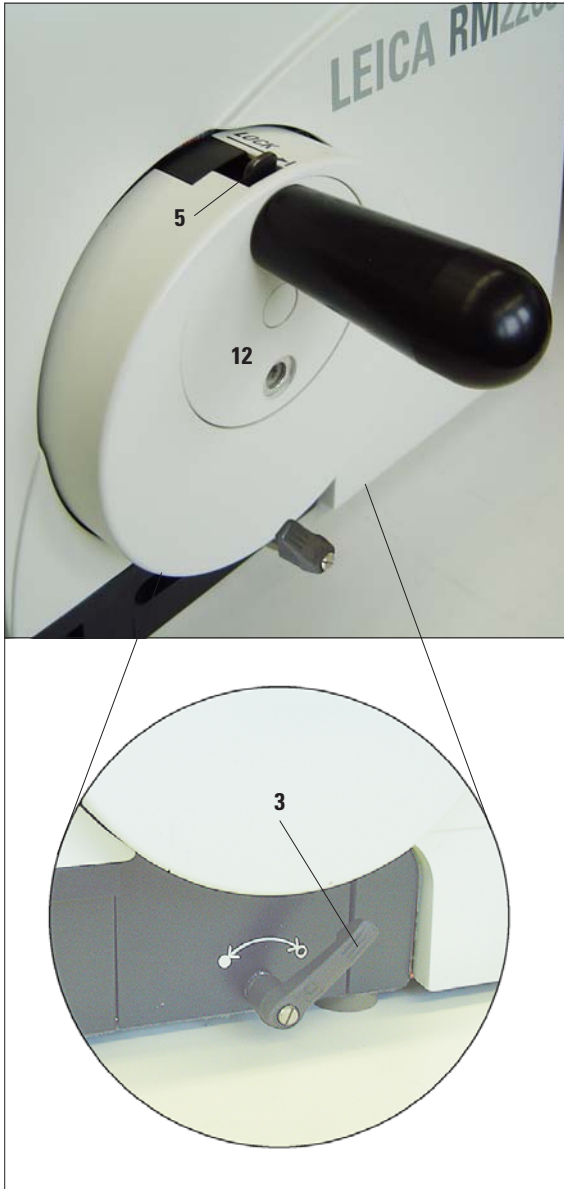

Fig. 2

Locking the handwheel

There are two ways of locking the handwheel (12):

Using the lever (3) on the right side of the microtome base plate, the handwheel can be braked in almost any position.

- To brake, rotate the lever in a counterclockwise direction to position ●.



Caution!

The braking lever (3) must be exactly in position ●, so that the handwheel brake is applied correctly. If the lever is moved beyond this point, it is possible that the handwheel is no longer braked.

- To unlock the handwheel brake turn the lever (3) back to its original position. Position O.
- To lock the handwheel, press the lever (5) outwards and continue to turn the handwheel slowly until it locks exactly in the 12 o'clock position.



When using both brake systems at the same time, always move the lever (3) to position O first. Otherwise, it may be not be possible to release the lever (5).

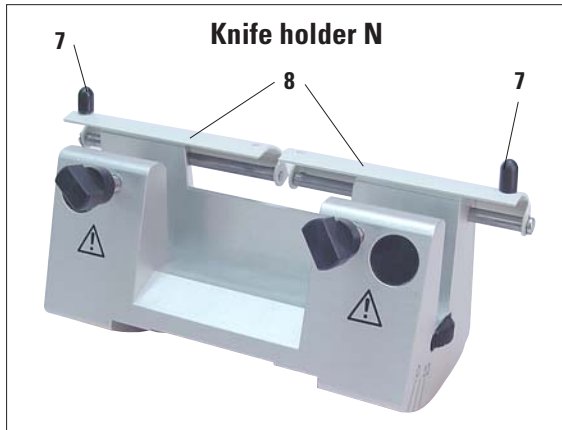

Fig. 3

Knife guard on the knife holder

Each knife holder is equipped with a tightly mounted knife guard (8, 9). This makes it possible to cover completely the cutting edge in every knife or blade position.

Knife holder N/NZ

The knife guard (8) of the knife holder N/NZ can be easily positioned via the two handles (7) (Fig. 3).

To cover the knife edge, push both cover strips of the knife guard to the center.

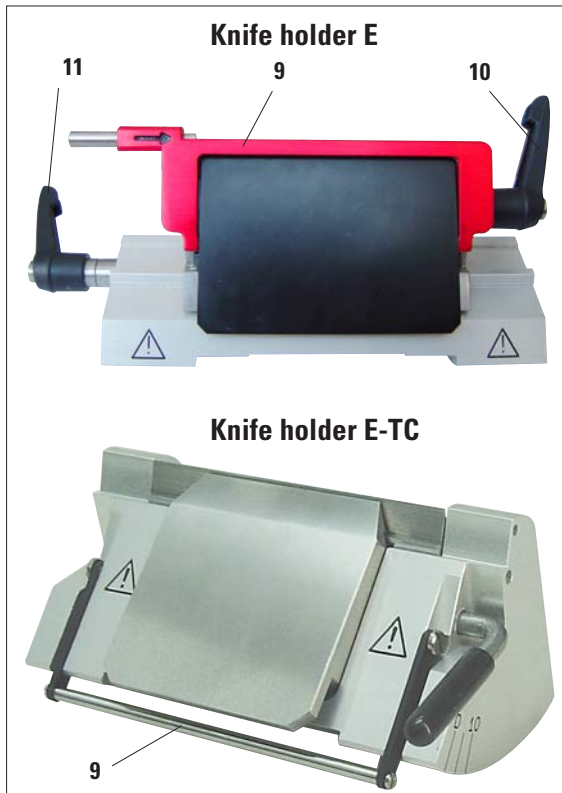

Fig. 4

Knife holder E/E-TC

The knife guard on knife holder E/E-TC consists of a red foldaway handle (9). To cover the cutting edge, fold the knife guard handle (9) upwards as illustrated in Fig. 4.



The clamping levers on the knife holder E are not interchangeable. The two clamping levers (10, 11) must remain in the position shown at all times, as otherwise isolated malfunctions of the knife holder can occur. Clamping lever for the blade (10) at the right, clamping lever for the lateral displacement (11) at the left.

3. Instrument components and specifications

3.1 Overview – instrument components

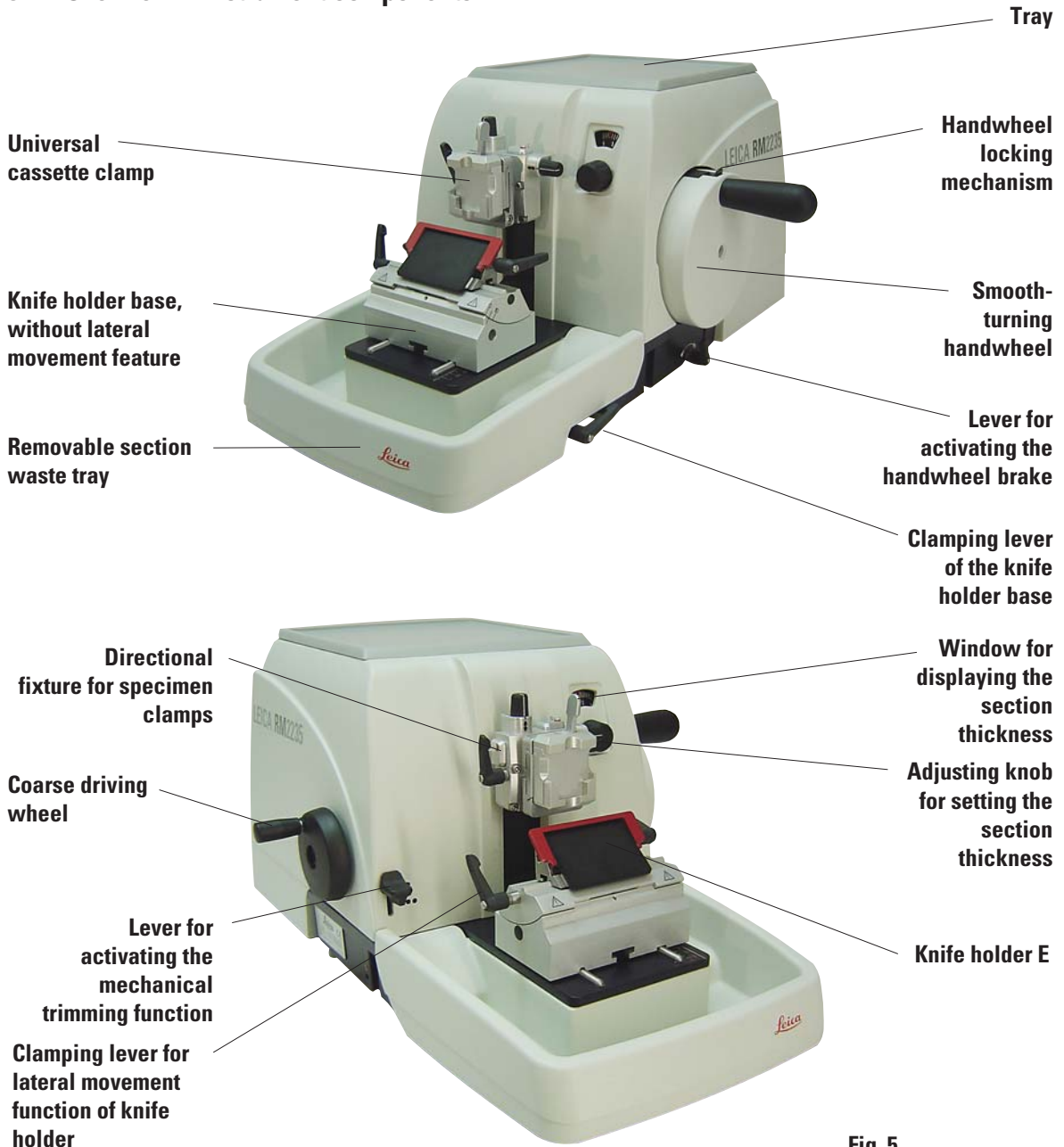

Fig. 5

3.2 Instrument specifications

Basic instrument with mechanical trim function, lateral coarse drive

The Leica RM2235 rotary microtome is equipped with a low-maintenance, -slack-free micrometer drive, with vertical and horizontal specimen feed realized via low-maintenance cross roller bearings.

The instrument is equipped with two independent handwheel locking systems for even greater operating safety.

Leica's patented, user-adjustable force balance system compensates centrifugal forces arising while cutting via a pretensioned spring for extremely light handwheel action.

Benefit: a heavy counterweight in the handwheel is no longer needed. The spring tension is individually adjustable, corresponding to the weight of the respective attached specimen clamp or specimen.

The patented specimen retraction system can be switched on and off by the user. The instrument thus offers all of the advantages of specimen retraction while supporting work in "rocking mode", i.e. without a full handwheel rotation.

We recommend disabling specimen retraction when working in "rocking mode".

The coarse drive wheel is ergonomically positioned.

(For more information on the rotating direction, see [chapter 5.1.2](#))

3. Instrument components and specifications

3.3 Technical data

General

Approvals:	The instrument-specific marks are located on the rear panel of the instrument next to the name plate.
Operating temperature range:	+10 °C to +35 °C
Temperature range during storage:	+5 °C to +55 °C
Relative humidity:	max. 80 % non-condensing
Humidity during storage:	< 80 %
Section thickness range:	1.0 - 60.0 µm
Section thickness settings:	from 1.0 - 10.0 µm in 1.0 µm increments from 10.0 - 20.0 µm in 2.0 µm increments from 20.0 - 60.0 µm in 5.0 µm increments
Specimen feed:	approx. 24 mm, ± 2 mm
Vertical stroke:	70 mm
Max. sectioning range without retraction:	69 mm (without specimen orientation at 1 µm)
Max. sectioning range with retraction:	62 mm
The specimen retraction can be turned off manually:	200 µm

Dimensions and weight

Width (including handwheel):	413 mm
Depth (including waste tray):	618 mm
Height (total):	305 mm (with tray on the hood)
Working height (knife blade):	168 mm (measured from the table)
Weight (without accessories):	approx. 37 kg

Optional equipment and optional accessories

Object orientation (option)	
horizontal:	8°
vertical:	8°
Rotating range:	± 90°
Trimming increments:	10 µm, 50 µm
Repositioning of knife holder base	
north-south:	± 25 mm

4.1 Standard delivery

The Leica RM2235 standard delivery includes:

1 Leica RM2235 basic instrument	
1 handwheel, complete	14 0500 38181
1 section waste tray	14 0502 37931
1 tool set – consisting of:	14 0500 38600
1 Allen key with handle, size 5	14 0194 04760
1 Allen key with handle, size 4	14 0194 04782
1 Allen key, size 3	14 0222 04138
1 screwdriver 3x50, 186 long	14 0170 11568
1 bottle (50 ml) of oil for drives, type 405	14 0336 06086
1 brush w/magnet	14 0183 40426
1 dust protective cover	14 0212 30350
1 operating manual D/E + language CD	14 0500 80001



The accessories ordered are included in a separate box. Carefully check the delivery against the packing list and the delivery note. Should there be any discrepancy, please contact the Leica selling unit handling your order.

4.2 Installation site requirements

- Stable, vibration-free laboratory bench with horizontal and even stage plate; practically vibration-free floor.
- No other instruments nearby which might cause vibrations.
- Room temperature permanently between +10 °C and +35 °C.
- Obstruction-free access to the handwheel.



Never operate the instrument in rooms with explosion hazard.

4. Startup

4.3 Unpacking and installation



When the instrument is delivered, check the tilt indicators on the packaging.

If the arrowhead is blue, the shipment was transported laying flat, was tilted at too great an angle or fell over during transport.

Note this on the shipping documents and check the shipment for possible damage.

Fig. 6

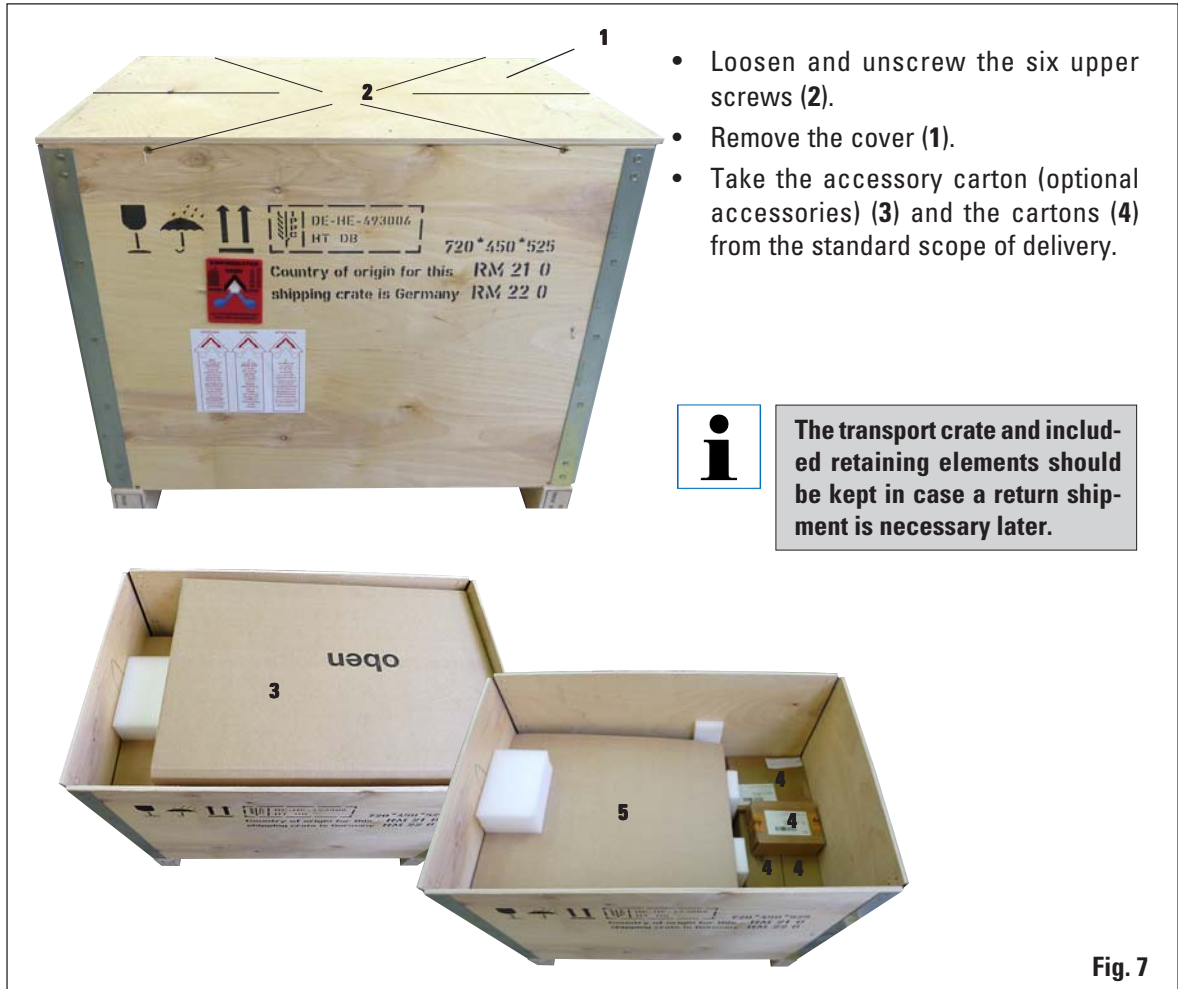

The transport crate and included retaining elements should be kept in case a return shipment is necessary later.

Fig. 7

4.3 Unpacking and installation (cont.)





Figure 8 illustrates the unpacking and installation process for the Leica RM2235 instrument. The top image shows the cardboard box with the fixing module (5) and the recessed grip (6) visible. The middle image shows a person lifting the instrument (7) out of the formed cushion (8). The bottom image is a technical drawing of the instrument (9) showing the sliding elements on the rear of the base plate.

- Take out the fixing module (5). To do so, hold it by the top edge of the module and in the recessed grip (6) and pull it out by pulling upwards.
- Lift the instrument (7) by holding it by the base plate and under the instrument on the back and lift it out of the formed cushion (8).



Never hold the instrument for transport by the handwheel or the rotary knob for section thickness adjustment.

- Place the instrument on a stable laboratory table. The two sliding elements (9) located on the rear of the base plate make it easier to move the instrument on the table.
- To move the instrument, hold it by the front of the base plate, lift it up gently and slide it on its slides.



Observe the correct resting angle to the table to avoid pinching your fingers.

Fig. 8

4. Startup

4.4 Assembling the handwheel



The handwheel has to be assembled before attempting to use the instrument.
The necessary parts and tools can be found in the tool-kit supplied in the delivery.

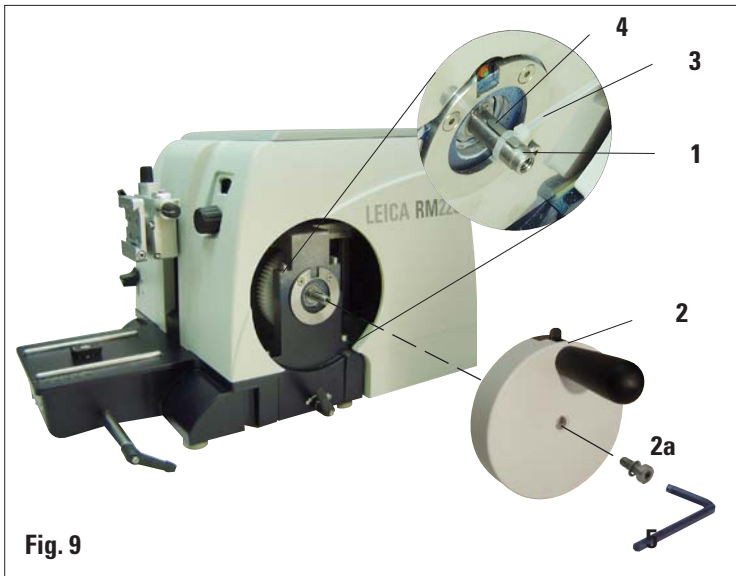

Fig. 9

The feather key (4) is loosely placed in the handwheel shaft (1) and fixed in place with a tie-rop during transport.

- Remove the cable tie (3).
Caution!
Make sure not to lose the feather key!
- Place the handwheel (2) on the handwheel shaft (1) as shown.
- Tighten the screw (2a) located in the center hole of the handwheel with an Allen key size 4 (5).
- Remove the cover foil from the self-adhesive cover disk and fix the cover disk on the handwheel.

4.5 Inserting the universal cassette clamp

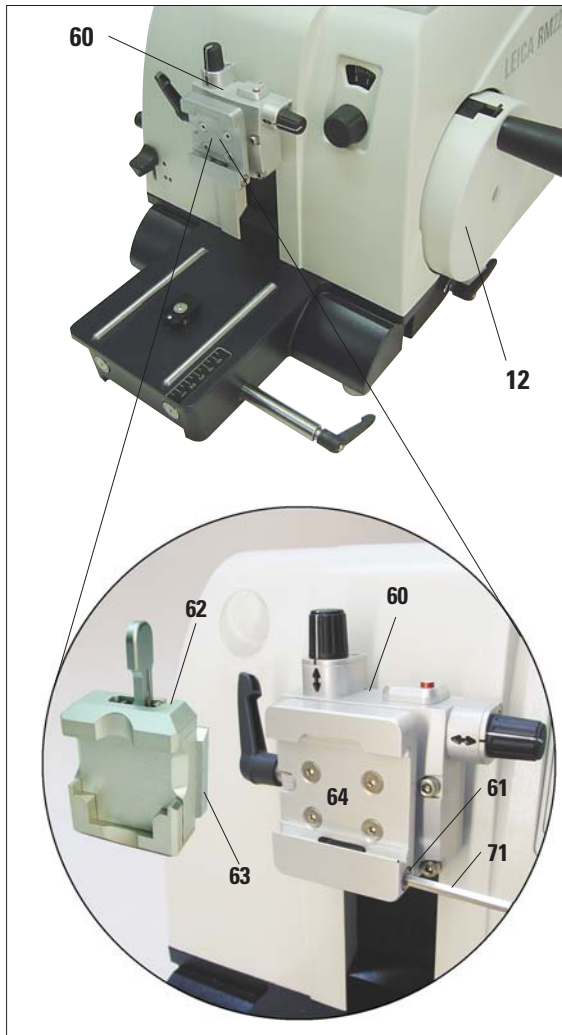

Fig. 10

There are two versions of the specimen holder, one with and one without specimen orientation, which are interchangeable.

The object orientation allows for simple position correction of the specimen surface when the specimen is clamped into place.

You can use the quick clamping system (64) to hold all available accessory specimen clamps (for more information, see [Chapter 6](#) "Optional accessories").

To do so, proceed as follows:

- Move the object head (60) to the upper end position by turning the handwheel (12) and engage the handwheel lock.
- To release the clamping system, turn the screw (61) of the quick clamping system (64) counterclockwise using an Allen key size 4 (71).
- Push the guide (63) of the universal cassette clamp (62) from the left into the quick clamping system (64) as far as it will go.
- To clamp the cassette clamp turn the screw (61) clockwise as far as it will go.



Since all stage clamps available as accessories are equipped with the same kind of guide on the back, they are inserted in the same way described here using the example of the cassette clamp.

4. Startup

4.6 Inserting the knife holder

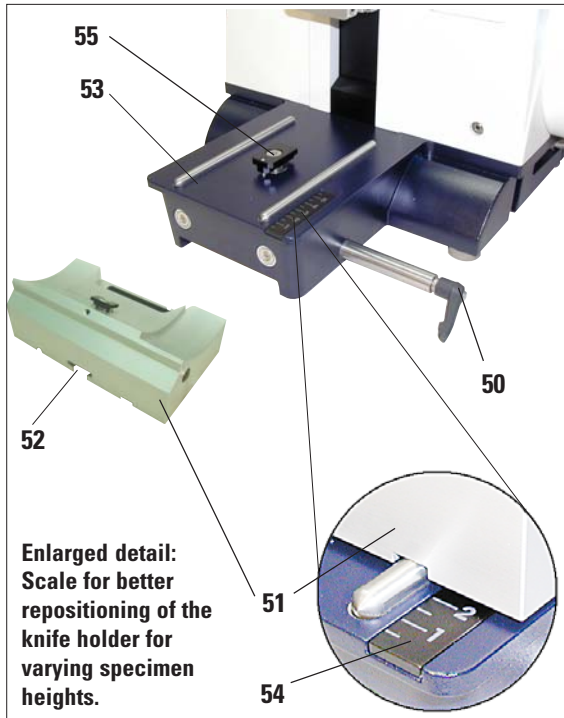

Fig. 11

Setting up the knife holder base

- Release the clamping lever (50) by rotating it counterclockwise.
- Insert the knife holder base (51) with the notch (52) on the bottom into the T-piece (55) of the microtome base plate (53).
- To secure the knife holder base, turn the clamping lever (50) clockwise.

The knife holder base (51) can be moved back and forth on the microtome base plate. This allows bringing the knife holder to optimal sectioning position in relation to the specimen.

There is a scale (54) on the right side of the microtome base plate. This enables faster and better positioning of the knife holder at the specimen if various combinations of standard specimens and specimen holders are used. The rear edge of the knife holder base (51) functions as the scale reference.

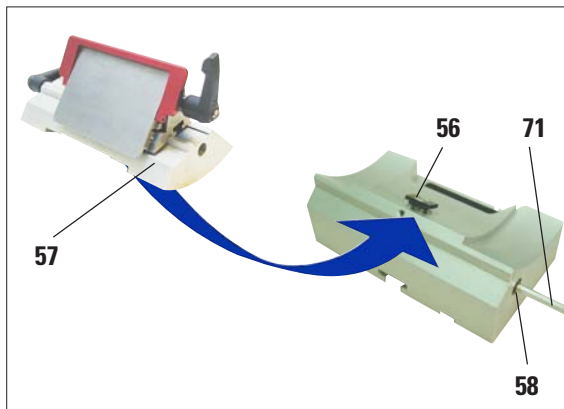

Fig. 12

Inserting the knife holder

- Loosen the screw (58) using an Allen key size 4 (71) until the knife holder (57) can be moved.
- Place the knife holder (57) with the underside groove onto the T-piece (56) of the knife holder base (51).
- To clamp, retighten the screw (58).

5.1 Operating elements and their functions

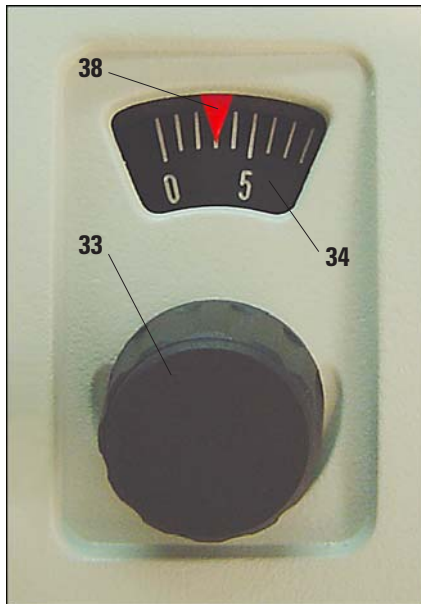

Fig. 13



Fig. 14

5.1.1 Section thickness setting

The section thickness is set by turning the adjusting knob (33) at the front of the microtome on the right.

The adjusting knob has a notch for each value that can be set.

Setting range: 1 - 60 μm

from 1 - 10 μm in 1 μm increments

from 10 - 20 μm in 2 μm increments

from 20 - 60 μm in 5 μm increments.

The section thickness set in each case is displayed in the window (34).

The selected section thickness (on the scale) must agree with the red pointer (38)

5.1.2 Coarse driving wheel

The instrument can be ordered with clockwise or counterclockwise rotation. The given direction of rotation means "forwards" and relates to the feed movement of the specimen towards the knife.

The coarse motion serves for a fast horizontal forwards movement of the object - towards the knife - and backwards - away from the knife.

When reaching the rear/front end positions, the coarse driving wheel can only be turned with difficulty. In the front end position, no more feed motion takes place.



The coarse driving wheel also turns during sectioning. Therefore it must not block whilst the handwheel is being turned during sectioning; otherwise, no feed motion can take place and thus also no sectioning.

5. Operation

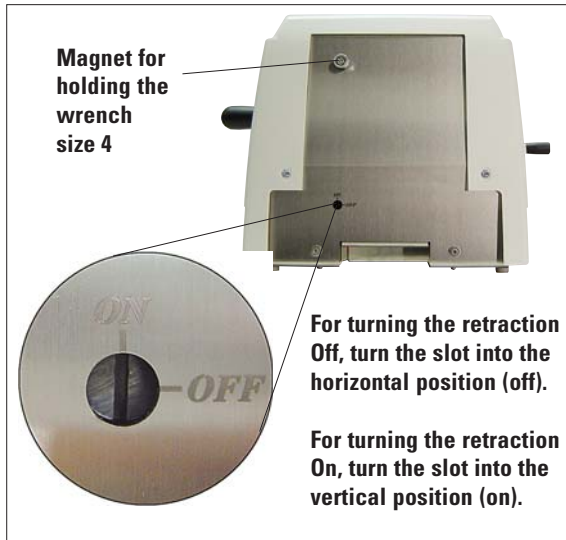

Fig. 15

5.1.3 Specimen retraction

The specimen retraction serves for protecting the knife and the specimen. When the retraction is switched on, the object is drawn back 200 μm into the upper end position after the sectioning stroke during the return movement. Before the feed motion of the new section thickness, the feed motion for the retraction value takes place.

The specimen retraction can be switched off manually at the back of the instrument (Fig. 15), if required, using the slotted-screwdriver supplied with the delivery.

Before switching the specimen retraction On and Off, run the object head to the upper end position by turning the handwheel.



Fig. 16

5.1.4 Mechanical trimming function

The RM2235 is fitted with a mechanical trimming function. The trimming lever has 3 notching positions (0, 10 μm , 30 μm).

The points (36) mark the two trimming stages:

- = 10 μm
- = 30 μm

- For activating the trimming function, press the lever downwards into one of the two notching positions and keep depressed. After each rotation of the handwheel, a feed motion of 10 μm or 30 μm takes place.
- After letting go of the lever, it automatically springs back to its original position (zero position). The trimming function is thereby deactivated.



The section thickness that has been set is not added to the selected trimming value.

If the section thickness that has been set is greater than the selected trimming value, the section thickness is fed.

5.1.5 Specimen holder with precision orientation



In the quick clamping device of the specimen holder fixture with precision orientation, all object clamps available as optional accessories can be used (implemented).

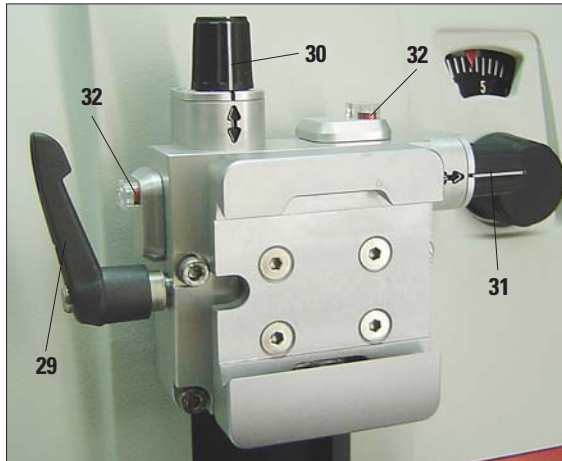

Fig. 17

Display of the zero position

For better display of the zero position, the orientation has two red indicators (32).

When both indicators are visible and both setscrews are in zero position at the same time (notch point, white marking on "↕"), the specimen is in zero position.



When the large standard specimen clamp (50 x 55 mm) is used, the specimen orientation of 8° in north-south direction is no longer possible. The usable angle is only about 4° in this case.

The object orientation allows for simple position correction of the specimen surface when the specimen is clamped into place.

Orienting the specimen

Specimen blocks must not be oriented during the retraction phase!
If a block is oriented during retraction, the block will advance by the retraction value PLUS the selected section thickness before the next section. This may cause damage to both specimen and knife!

- Raise the object head to the upper end position and activate the handwheel lock.
- To release the clamp, turn the eccentric lever (29) forwards.
- Turn setscrew (30) to orient the specimen in north-south direction. Turn setscrew (31) to orient the specimen in east-west direction. Each complete turn of the screw inclines the specimen by 2°. A total of 4 complete turns = 8° are possible in every direction. The accuracy is approximately $\pm 0.5^\circ$. For ease of estimation, there is a white marking on the handle and a notch point that is noticeable during turning.
- To lock the current orientation, turn the eccentric lever (29) backwards.

5. Operation

5.2 Adjusting the clearance angle

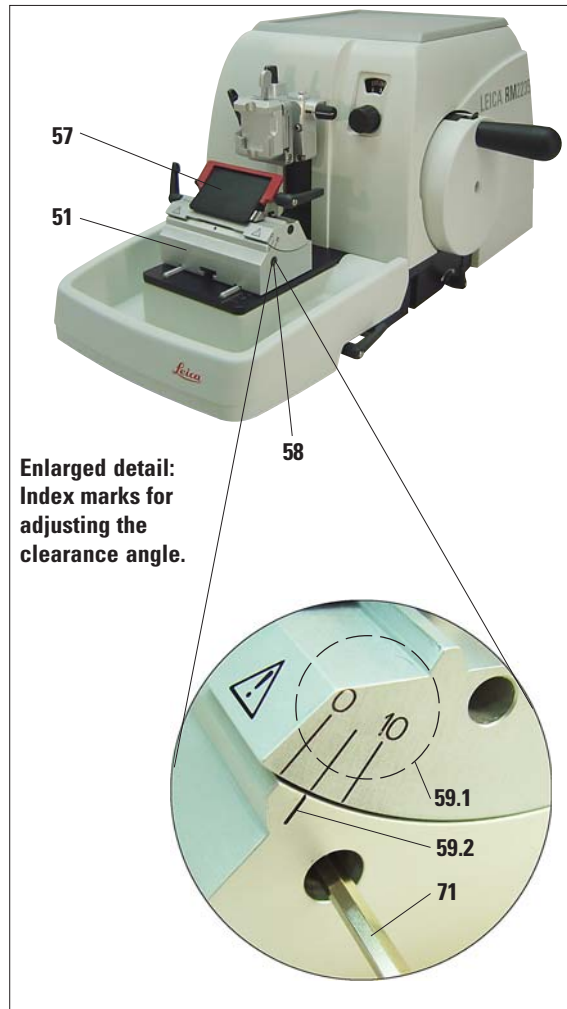

Fig. 18

- The index marks (0°, 5° and 10°) for adjustment of the clearance angle (59.1) are located on the right side of the knife holder (57).
- There is also an index mark (59.2) on the right side of the knife holder basis (51) which serves as a reference point when adjusting the clearance angle.
- Loosen the screw (58) using an Allen key size 4 (71) until the knife holder (57) can be moved.
- Move the knife holder until the index mark of the desired clearance angle coincides with the reference line on the knife holder base.
Example:
Enlarged detail showing a clearance angle setting of 5°.



The recommended clearance angle setting for knife holder E is approx. 5°.

- Hold down the knife holder in this position and retighten the screw (58) for clamping.



Fig. 19

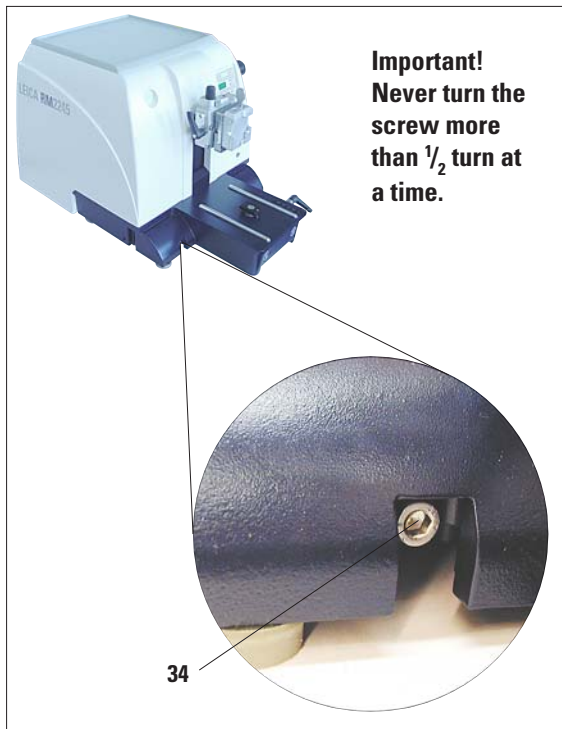

Fig. 20

5.3 Fine adjustment of the force balance

If another accessory of a different weight is mounted on the object head (33), you must check whether it is necessary to readjust the force balance.

Checking the correct setting:

- Attach the new accessory and clamp the specimen.
- Set the object head to half the height of the vertical travel range by turning the hand-wheel (Fig. 19).

If the object head remains in this exact position, the setting is correct.

If the object head moves, i.e. it is raised or lowered, fine adjustment is necessary.



Failure to adjust the force balance may result in injury while working.

The force balance is adjusted using the screw (34), which can be accessed by removing the section waste tray on the bottom of the base plate of the microtome. Use the Allen key provided, size 5 (with handle!) for the adjustment.

- If the object head moves **downwards**, turn the screw approx. $\frac{1}{2}$ turn **clockwise**.
- If the object head moves **upwards**, turn the screw (34) approx. $\frac{1}{2}$ turn **counterclockwise**.
- Continue this procedure until the object head no longer moves once released.

5. Operation

5.4 Clamping the specimen



Always clamp the specimen block BEFORE clamping the knife. Lock the handwheel and cover the knife edge with the knife guard prior to any manipulation of knife or specimen, prior to changing the specimen block and during all work breaks!

- Rotate the handwheel until the specimen clamp is in the uppermost position.
- Block the handwheel (allow lever (5) Fig. 2 to notch) and activate the brake.
- Insert a specimen block into the specimen clamp.



A detailed description for inserting the specimen into various specimen clamps and specimen holders is provided in [Chapter 6](#) "Optional accessories".

5.5 Clamping the knife / disposable blade



Be very careful when handling microtome knives or blades. The cutting edge is extremely sharp and can cause severe injury!

- Carefully insert knife or disposable blade into the knife holder and clamp.
- Make sure that the blade is clamped parallel to the upper edge of the pressure plate.
(For more information see [Chapter 6.3.2, Fig. 33](#))



A detailed description for inserting the blade or the knife into the individual knife holders is provided in [Chapter 6](#), "Optional accessories".

5.6 Sectioning



Always turn the handwheel evenly in clockwise direction; otherwise, the brake will not work properly. The rotation speed of the handwheel must be adapted to suit the hardness of the specimen.

For harder specimens, use a slower speed.

Cutting into the specimen (trimming)



- Run the specimen to the rear end position by turning the coarse driving wheel.
- Push the knife holder on the knife-holder base almost until it is just before the object.
- Orientate the position of the specimen surface (only in the case of specimen holders that can be orientated).
- Release the handwheel lock, or handwheel brake, respectively.
- Using the trimming lever select the required trimming stage.
- Begin the cutting process by turning the handwheel.
- Stop the cutting process when the required specimen level has been reached.
- Let go of the trimming lever.

Remove the sections



- Set the required section thickness, or check the value setting on the display, respectively.

Always use a different area of the cutting edge for trimming and sectioning.

- To do so, laterally displace the blade or knife in the knife holder. When using the knife holder E with lateral movement, it is sufficient to move the knife holder sideways.
- For sectioning, turn the handwheel evenly in a clockwise direction.



Take care not to block the coarse driving wheel when turning the handwheel!

Otherwise there will be no feed motion of the section thickness and thus no sectioning will occur.

- Pick up the sections and mount them on microscope slides.

5. Operation

5.7 Changing the specimen or interrupting sectioning



Lock the handwheel and cover the knife edge with the knife guard prior to any manipulation of knife or object head, as well as prior to changing the specimen block and during all work breaks!

- Raise the specimen to the upper end position and activate the mechanical handwheel lock.
- Cover the sectioning edge with the knife guard.
- Remove the specimen from the specimen clamp and mount a new sample to continue.
- Run the object clamps with the coarse driving wheel back far enough until the new specimen can start being cut.

5.8 Finishing daily routine

- Raise the specimen to the upper end position by turning the handwheel and engage the handwheel lock.



Always remove the knife / blade before detaching the knife holder from the instrument.

Always put the knives back into the knife case when not in use!

Never place a knife anywhere with the cutting edge facing upwards and never try to catch a falling knife!

- Remove the blade from the knife holder and insert it in the receptacle at the bottom of the dispenser, or remove the knife from the knife holder and put it back in the knife case.
- Remove the specimen from the specimen clamp.
- Push all section debris into the section waste tray and empty the tray.
- Clean the instrument (see [Chapter 8.1](#)).

6.1 Assembly for fixture for specimen clamps



Depending upon the purchase order, the basic instrument is delivered with the directional or rigid fixture for specimen clamps which must be assembled first. All specimen clamps available as accessories can be used in both fixtures for specimen clamps.

Before assembling the fixture for specimen clamps, activate the mechanical handwheel lock!

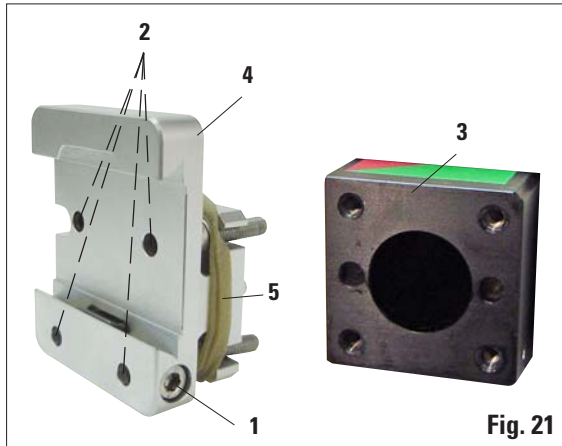

Fig. 21

6.1.1 Rigid fixture for specimen clamps

- Screw the rigid fixture for specimen clamps (4) onto the object head (3): Remove the screw (1), place the fixture for specimen clamps (4) onto the object head (3) from the front and tighten the screws (2) with an Allen key size 3. Next, insert the screw (1) from the side and briefly tighten it with an Allen key size 4.



Remove the rubber ring only after attaching the object head!

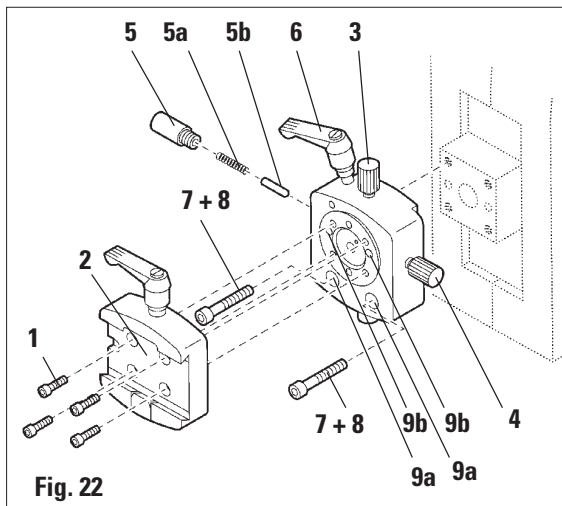

Fig. 22

- Finally, place the dovetail holder (2) and fasten by screwing in the 4 screws (1) using an Allen key size 3.

6.1.2 Directional fixture for specimen clamps

- Loosen the eccentric bolt (6) by turning it counterclockwise.
- Completely unscrew the thrust piece (5) with a flat-tip screwdriver and pull it out with spring (5a) and pin (5b).
- Completely unscrew the setscrews (3) and (4).
- Attach the directional fixture for specimen clamps as shown.
- Insert the screws (7+8) in the bore (2 screws (8) are accessible through the bore (9a)) and evenly screw them in using a size 3 Allen key.
- Insert the spring (5a) and pin (5b) with the flatter side into the thrust piece (5). Completely screw in the thrust piece with a flat-tip screwdriver.
- Completely screw in the setscrews (3+4).

6. Optional accessories

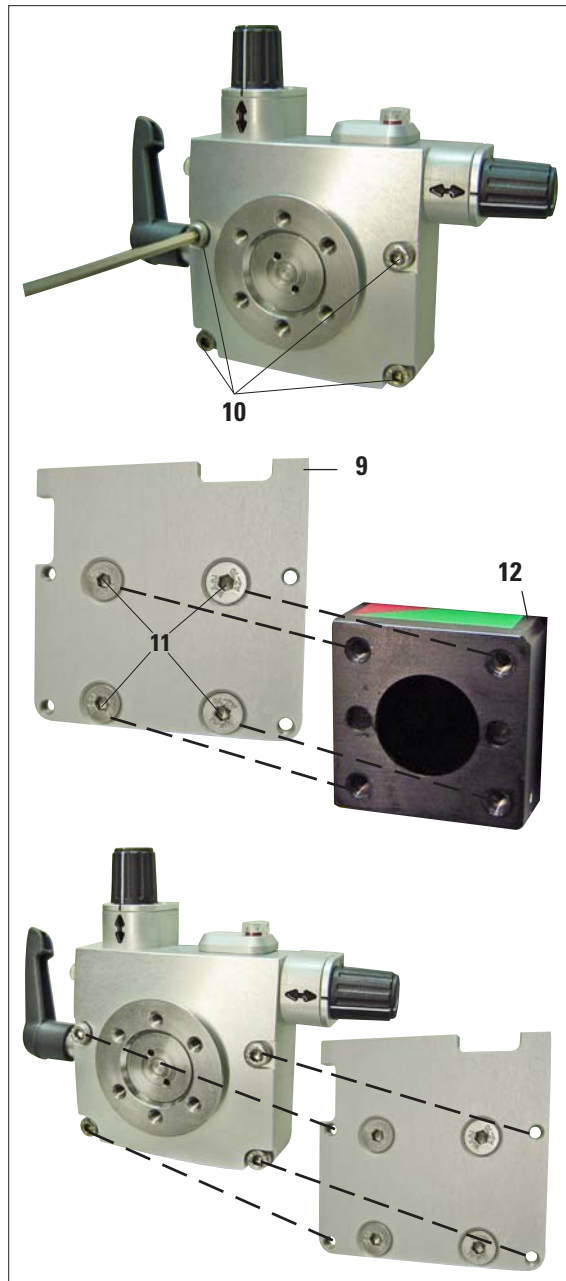

Fig. 23

6.1.3 Fine-directional fixture for specimen clamps

- Before the fine-directional fixture for specimen clamps can be mounted, loosen 4 screws (10) (Allen key size 3) and carefully remove the fixture for specimen clamps from the baseplate (9).
- Using the 4 supplied screws (11) and the Allen key size 3, fasten the baseplate to the specimen head (12).
- Now, screw the fine-directional fixture for specimen clamps with the 4 screws (10) and the Allen key size 3 onto the object head.



If the fine-directional fixture for specimen clamps is not used, retain the baseplate and 4 screws (11) together with the fine-directional fixture for specimen clamps!

6.1.4 Quick clamping system

It is used as specimen holder for use with the fine-directional fixture for specimen clamps with zero point indicators or the directional fixture for specimen clamps.

- Screw the 4 screws (**13**) into bore **A** with an Allen key size 2.5 and tighten them.

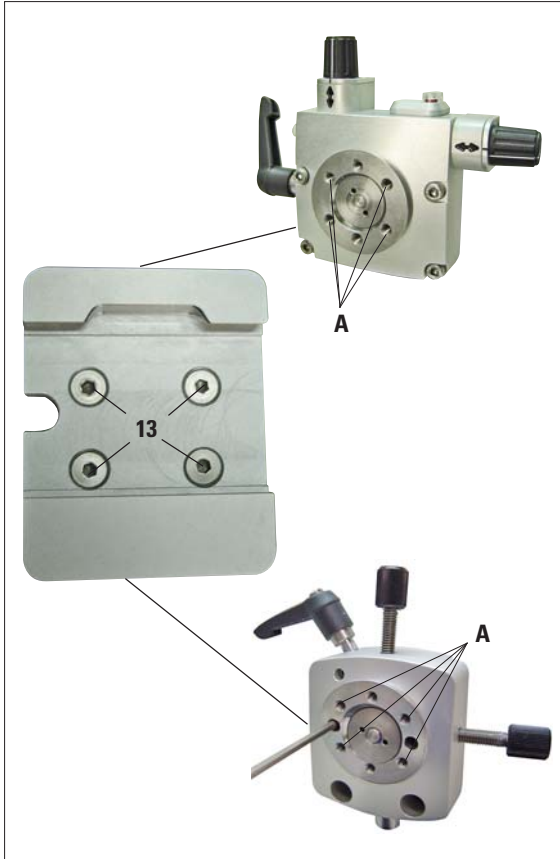

Fig. 22

6. Optional accessories

6.2 Specimen clamps and holders



All specimen clamps available as accessories can be integrated into either the directional or non-directional specimen holder fixture.

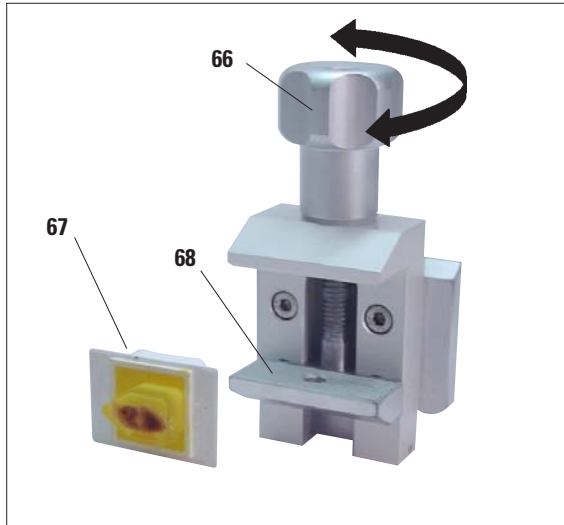

Fig. 25

6.2.1 Standard specimen clamp

The standard specimen clamps are available in two sizes: 40 x 40 mm and 50 x 55 mm. They are designed for direct clamping of rectangular blocks. In addition, they accommodate the foil clamps.

- Turn the knurled screw (66) counterclockwise to move the movable jaw (68) downward.
- Mount the sample (67) as required.
- Turn the knurled screw (66) clockwise to move the movable jaw upward against the fixed jaw to securely clamp the sample.

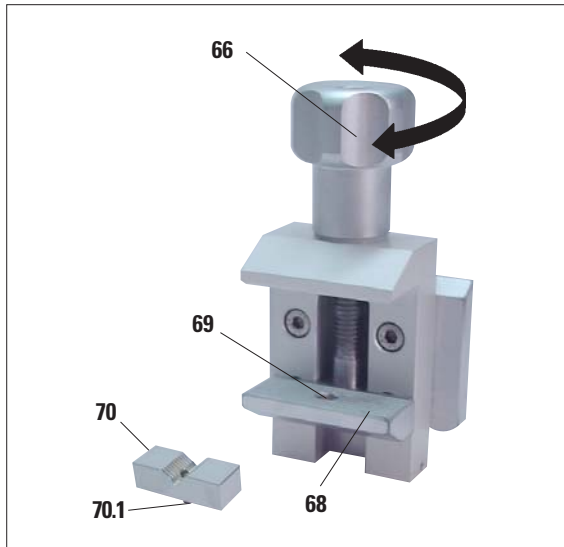

Fig. 26

6.2.2 Vee insert

The vee insert (70) is mounted in the hole provided in the lower movable jaw of the standard specimen clamp.

This makes it possible to clamp round specimens in the standard specimen clamp.

- Turn the knurled screw (66) counterclockwise to move the movable jaw (68) downward.
- Insert the pin (70.1) of the vee insert (70) in the hole (69) of the lower jaw (68).
- Mount the sample as required.
- Turn the knurled screw (66) clockwise to move the movable jaw with the vee insert upward against the fixed jaw to securely clamp the sample.

6.2.3 Foil clamp type 1

The foil clamp type 1 is appropriate both for clamping very small foil pieces and flat, angular samples. It is mounted in the standard specimen clamp.

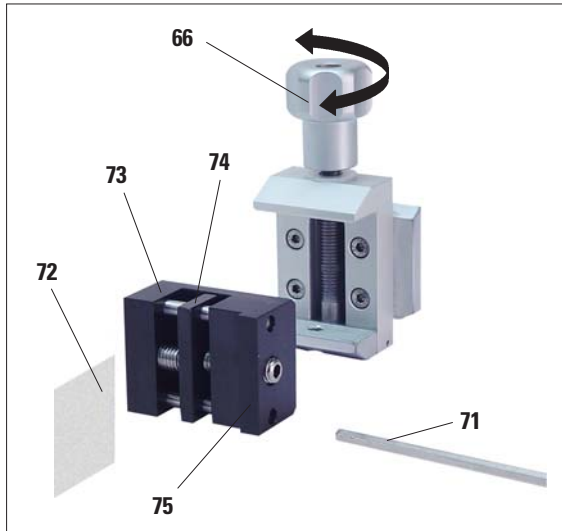

Fig. 27

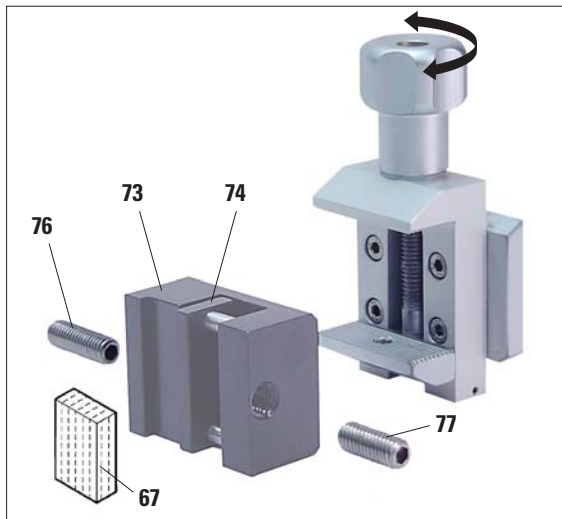

Fig. 28

Clamping of foil pieces

- Move the movable jaw (74) to the right as required by turning the set screw with an Allen key size 4 (71).
- Place the foil (72) between the movable jaw (74) and the fixed jaw (73).
- To clamp the foil, screw the movable jaw (74) against the fixed jaw (73) by using the Allen key.
- Insert the foil clamp (75) in the standard specimen clamp as shown.
- Turn the knurled screw (66) clockwise to clamp the foil clamp in the standard specimen clamp.

Clamping of flat, angular samples

To clamp angular samples, replace the long set screw (76) with the short set screw (77) provided with the foil clamp.

- Unscrew the long set screw (76) to the left with an Allen key size 4 (71).
- Screw the short set screw (77) in the hole.
- Place the sample (67) between the movable jaw (74) and the fixed jaw (73).
- To clamp the sample, screw the movable jaw (74) by turning the set screw (77) against the fixed jaw (73).
- Insert the foil clamp in the standard specimen clamp as shown.
- Turn the knurled screw (66) clockwise to clamp the foil clamp in the standard specimen clamp.

6. Optional accessories

6.2.4 Foil clamp type 2



The foil clamp type 2 is appropriate for large foil ribbons. It is mounted in the standard specimen clamp.

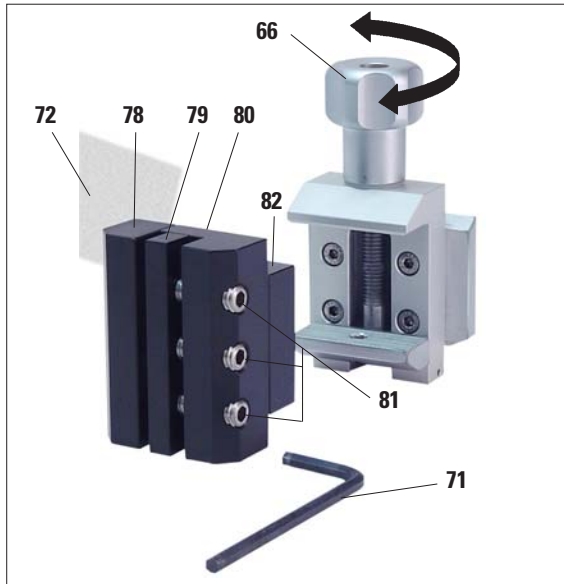

Fig. 29

- To open the jaws (78) and (79) lightly loosen the 3 screws (81) with an Allen key size 4 (71).
- Insert the foil ribbon (72) from behind to position it between the movable jaw (79) and the fixed jaw (78).
- To clamp the foil, first tighten the screw in the middle and then the other two screws (81) with the Allen key (71).
- Place the foil clamp (82) in the standard specimen clamp so that the beveled surface (80) on the back of the foil clamp points to the right or left.
- Turn the knurled screw (66) clockwise to securely clamp the foil clamp in the standard specimen clamp.

6.2.5 Universal cassette clamp

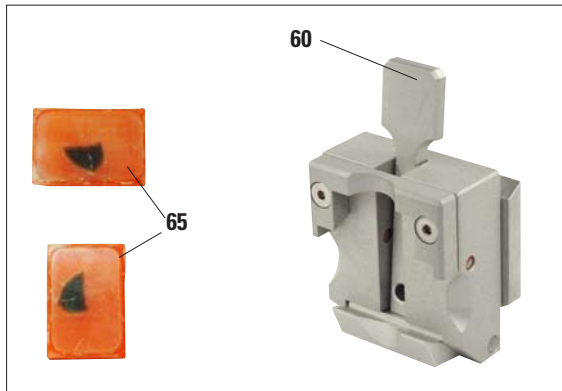

Fig. 30



The universal cassette clamp (UCC) is designed to for horizontal or vertical clamping of all kinds of commercial cassettes. Laboratory personnel **MUST** check correct, firm seating before cutting.

- Push the lever (60) forwards.
- Mount the cassette (65) horizontally or vertically as required.
- To clamp the cassette, release the lever (60).

Universal cassette clamp, ice-cooled

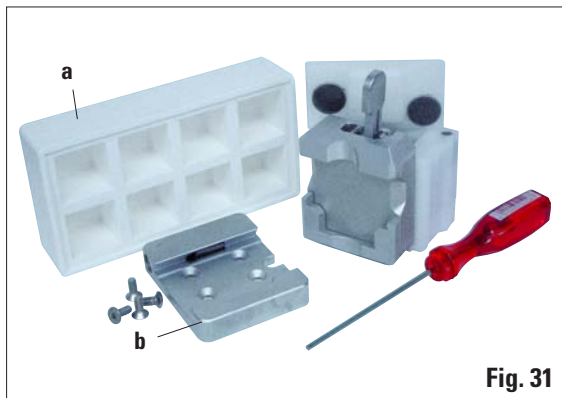

Fig. 31



Use the ice-cooled UCC with the non-directional specimen holder fixture only!

- Ice cubes can be made using the included Paraflex mold (a).
- Quick clamping system (b), see page 31.

6. Optional accessories

6.2.6 Super mega-cassette clamp

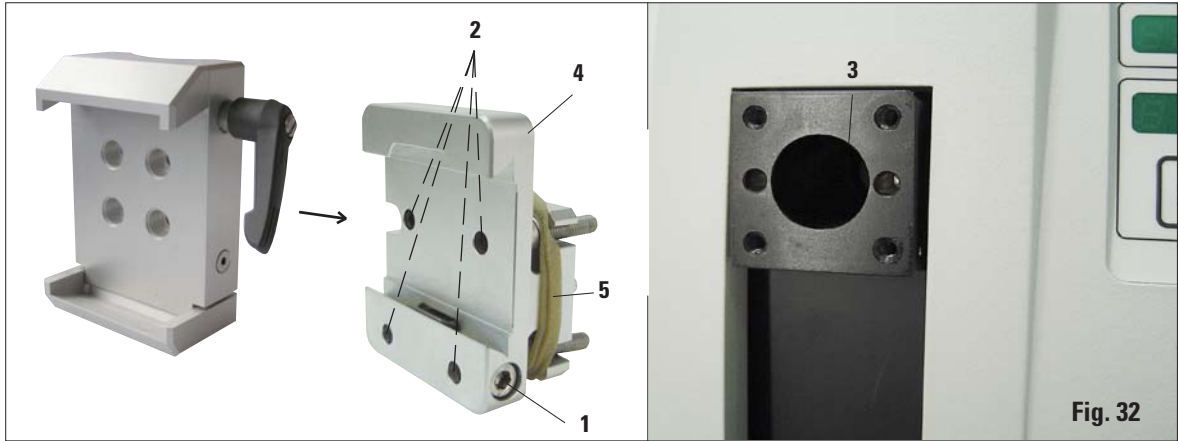

Fig. 32

Assembly of the super mega-cassette clamp

The super mega-cassette clamp should preferably be used with the rigid fixture for specimen clamps.

To do so, proceed as follows:



Remove the rubber ring (5) only after having attached the cassette clamp on the object head!

- Screw the rigid fixture for specimen clamps (4) onto the object head (3): Remove the screw (1), place the fixture for specimen clamps (4) onto the object head (3) from the front and tighten the screws (2) with an Allen key size 3.
Next, insert the screw (1) from the side and briefly tighten it with an Allen key size 4.
- Insert the super mega-cassette clamp from the side on the left into the dovetail guide of the rigid fixture for specimen clamps and tighten screw (1).



If the directional fixture for specimen clamps is used with the rigid knife holder base, the orientation must be in position "0" and the cover for backlighting illumination must be detached. (Danger of collision if not observed!)

NEVER use the super mega-cassette clamp with backlighting illumination!

6.2.7 Holder for round specimens



The holder for round specimens is designed to accommodate cylindrical samples. Inserts for specimens of 6, 15 and 25 mm diameter are available.

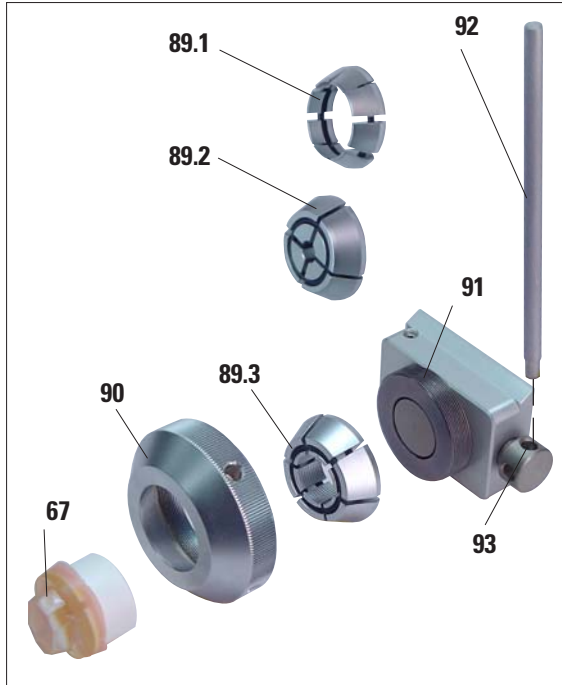

Fig. 33

- To mount the required insert (**89.1-3**) turn the clamping ring (**90**) counterclockwise and remove it.
- Place the required insert into the tension ring (**90**) and screw the tension ring onto the thread (**91**) by turning it clockwise.
- Mount the sample (**67**) and fix by turning the clamping ring (**90**) clockwise.
- To orient the inserted sample, insert the pin (**92**) into the bore (**93**) and rotate it counterclockwise to release the clamp. You can now rotate the specimen so that the side you want faces upwards.
- To lock it in the position you have chosen, tighten the pin (**92**) by turning it clockwise.

6. Optional accessories

6.3 Knife holder base and knife holder



Fig. 34

The plastic handles of all clamping levers on the instrument and knife holders can be turned to the position that is most convenient for each user.

Pull the grip (94) out of the lever, hold it in this position, and rotate it to the desired position. It will then lock automatically when released.

6.3.1 Knife holder base, without lateral movement feature

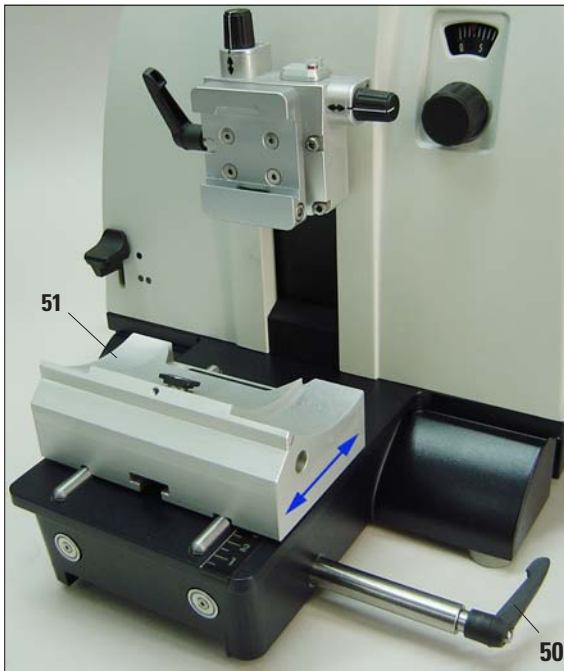

Fig. 35

Repositioning the knife holder base

The one-piece knife holder base (rigid) (51) can be moved forwards and backwards on the microtome base plate.

This vertical displacement allows bringing the knife holder into the optimal cutting position in relation to the specimen.

- To release, rotate the clamping lever (50) on the right side of the microtome base plate counterclockwise.
- Reposition the knife holder together with the knife holder base forward or backward as appropriate.
- Secure the clamping mechanism by rotating the lever (50) clockwise.

6.3.2 Knife holder E/E-TC



The knife holder E-TC is designed for the Leica TC-65 tungsten carbide blades.



Prior to inserting the blade, both knife holder and knife holder base must have been installed on the instrument!

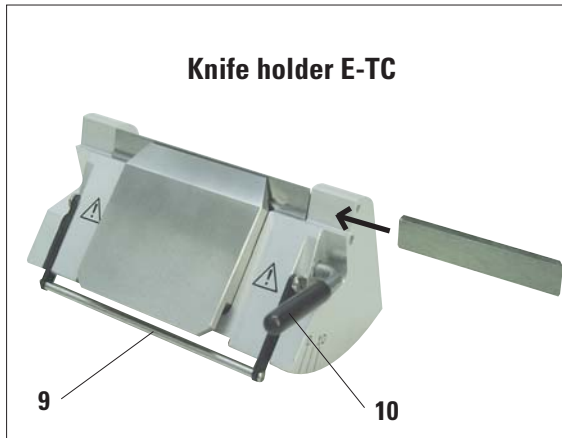

Fig. 36

Inserting the blades, knife holder E and E-TC

- Fold knife guard (9) downward.
- To insert the blade, flap the right clamping lever (10) forward and down.
- Carefully insert the blade from the side. Make sure that the blade is clamped parallel to the upper edge of the pressure plate.
- To clamp the blade, rotate clamping lever (10) back upwards.



The knife holder E is designed for conventional disposable blades from all current manufacturers. It is available in two models: one for narrow-band blades and one for broad-band blades. The knife holder has a lateral movement, so that the entire width of the blade can be used.

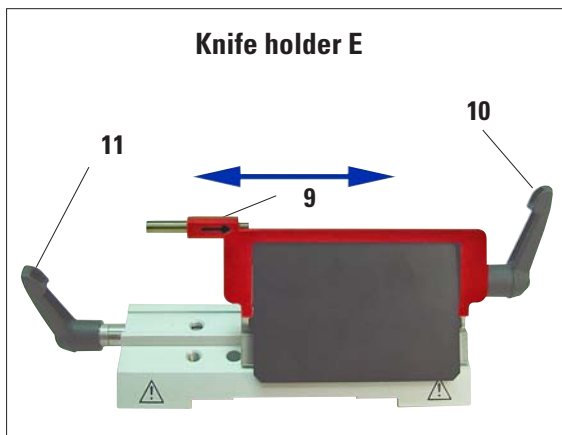

Fig. 37



The clamping levers on the knife holder are not interchangeable. The two clamping levers (10, 11) must remain in the position shown at all times, as otherwise isolated malfunctions of the knife holder can occur.

Clamping lever for the blade (10) at the right, clamping lever for the lateral displacement (11) at the left.

6. Optional accessories

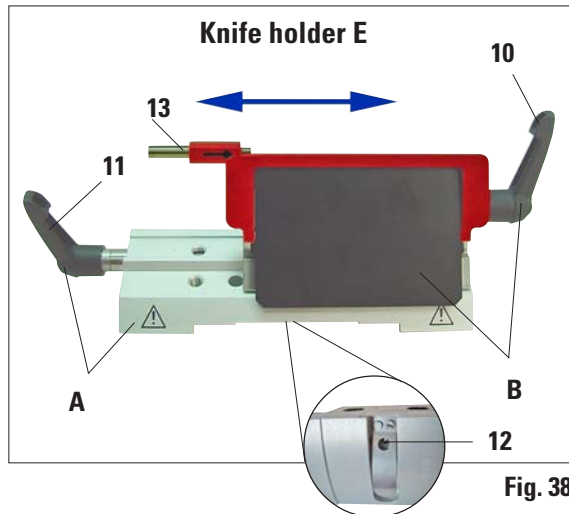

Fig. 38

Lateral displacement (only for knife holder E)

The lateral movement feature of the knife holder base enables the use of the entire length of the blade or knife, eliminating the need for readjusting the knife holder. The knife holder E consists of a segment arch **A** (with lever **(11)**) and the clamp mount **B** (with lever **(10)** and ejector **(13)**).

The extreme left and right positions as well as the middle position are each marked with a notch point.

- To release the clamp, rotate the lever **(11)** on the left side of the knife holder forwards.
- Move the knife holder sideways.
- To clamp, rotate the lever **(11)** back.

Note on the knife holder E:

The knife holder E is an important precision component, the quality and precise adjustment of which have a lasting effect on the entire function of the microtome. In case of malfunctions or damages to the clamp mount, it is always required to replace the clamp mount, including the pertinent clamping lever.

Leica Biosystems offers special prices for new clamp mounts in case of damages to the clamp mount after the warranty has expired.

In this way, perfect function of the device can be ensured over the course of many years.

Setting of the clamping system of the clamp mount on the segment arch

To ensure a proper sectioning result, clamp mount B must be securely clamped onto segment arch A.

The clamping is carried out using an eccentric at the lever **(11)**. The clamping force is adjusted with the setscrew **(12)** on the underside of the segment arch. The setting of the clamping is carried out so that the clamping lever can be rotated to the stop with constantly increasing resistance.

Adjust the clamping with a 2.5mm Allen key at the setscrew **(12)** so that the lever initially "bars" when the lever is activated. Continue turning the setscrew **(12)** a little bit (approx. $\frac{1}{4}$ turn to the left or right), then check that the lever no longer "bars", but also does not jam "heavily".

(The language CD features a short video film for this purpose.)

Knife holder E with water bath for narrow-band and broad-band blades

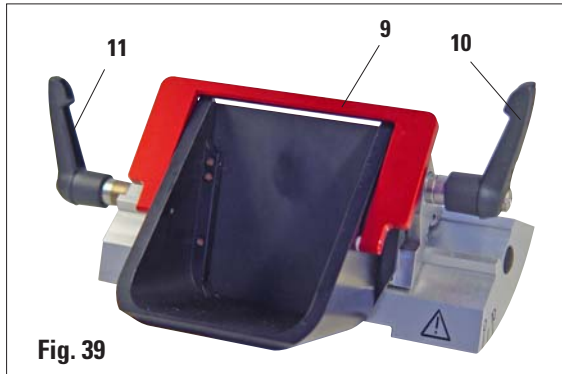

Knife holder E with water bath is available for both narrow-band and broad-band blades.

The knife guard on knife holder E consists of a red foldaway handle (9). To cover the cutting edge, fold the knife guard handle (9) upwards as illustrated in Figure.



The clamping levers on the knife holder are not interchangeable. The two clamping levers (10 and 11) must remain in the position shown at all times, as otherwise isolated malfunctions of the knife holder can occur.

Clamping lever for the blade (10) at the right, clamping lever for the lateral displacement (11) at the left.

Use

Floating thin paraffin sections (for example, for subsequent immunostaining procedures) on the surface of the water. Flat paraffin sections can be removed from the surface of the water using glass slides.



The vessel is filled with water up to the blade. After trimming, remove the section waste from the tray and create the sections to be prepared. The sections floating on the surface of the water can be removed using the glass slide.

6. Optional accessories

6.3.3 Knife holder N/NZ



The knife holders N and NZ are appropriate for standard steel and tungsten carbide knives, profile c and d, up to 16 cm long. The integrated height adjustment feature allows you to also use knives that have been resharpened numerous times.

Mounting the knife support bar

- Push knife guard (8) to the center.
- Set the knife support bar (46) onto the height adjustment screws (not visible) in the position shown. The flat ends of the height adjustment screws must be located in the slots at each end of the knife support bar.



Prior to inserting the knife, both knife holder and knife holder base must have been installed on the instrument!

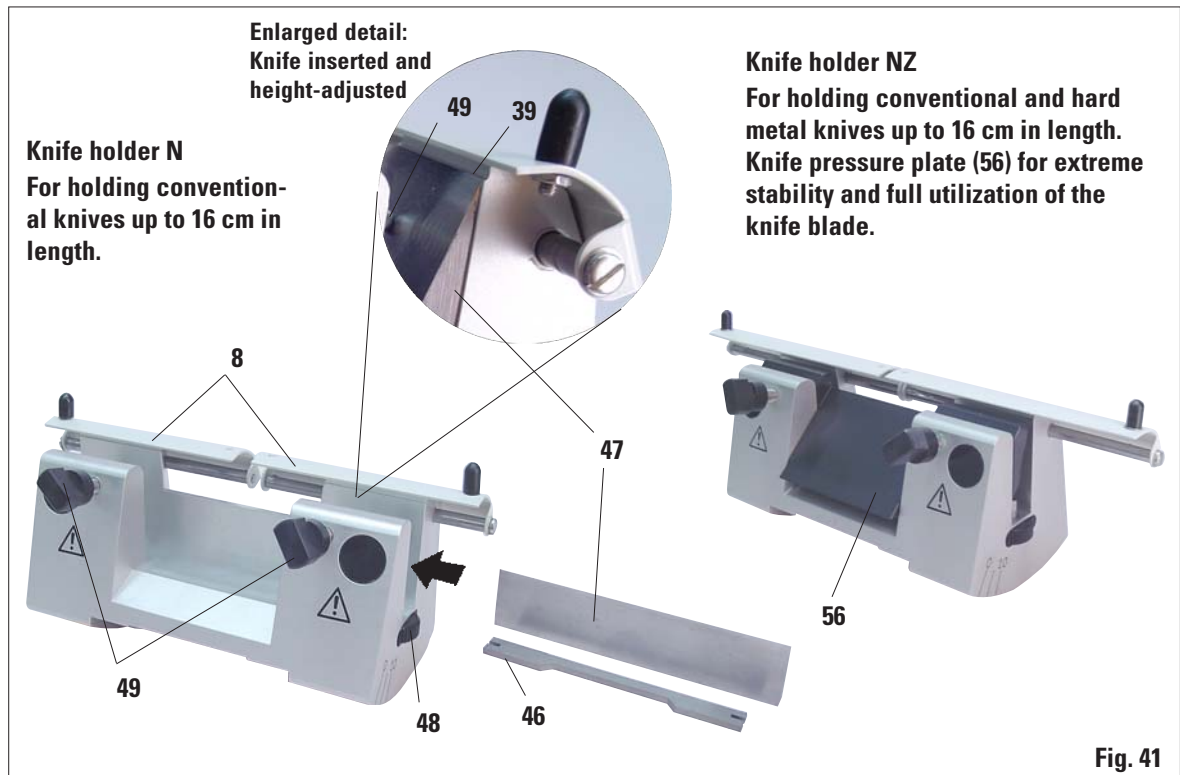

Inserting the knife

- Rotate the knurled nuts **(48)** on the right and left of the knife holder forward in opposite directions, lowering the knife support bar to the lowest possible position, thus ensuring that the knife edge will not be damaged when inserting the knife.
- Unscrew the clamping screws **(49)** as far out as possible (rotate counterclockwise).
- Hold the knife **(47)** at the knife back and carefully insert it in the holder from the side as shown with the cutting edge facing upward.

Knife height adjustment

When adjusting the clearance angle, the knife edge should be positioned as exactly as possible in the actual center of rotation of the knife holder. The lay-on edge **(39)** of the rear clamping chucks serves as a reference position for correct knife height adjustment. The knife edge should be parallel with the locating edges.

- Rotate the knurled nuts **(48)** uniformly and backwards until the knife blade is parallel to the lay-on edge **(39)** (see detailed illustration) of the rear clamping chucks.
- To clamp the knife **(47)** evenly screw the two knife clamping screws **(49)** inward (rotate clockwise).

Lateral repositioning of the knife

- Push knife guard **(8)** to the center.
- Loosen the clamping screws **(49)** by turning them counterclockwise.
- Push the knife **(47)** to the left or right as required.
- To clamp the knife **(47)**, always tighten the clamping screw **(49)** first which is located on the side to which the knife has been repositioned by turning it clockwise.

6. Optional accessories

6.4 Section waste tray

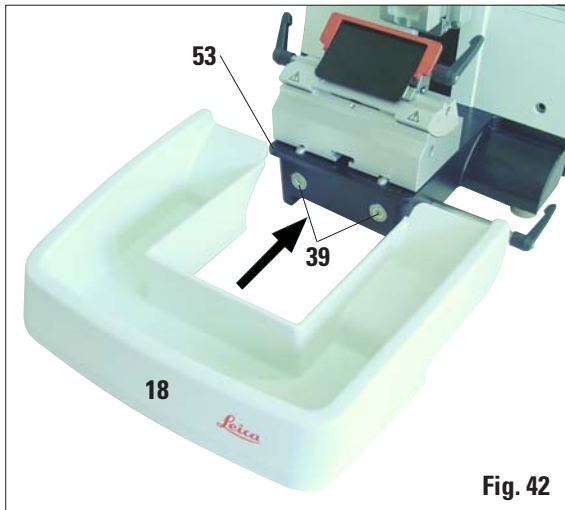

Fig. 42

- Push the section waste tray (18) from the front to the microtome base plate (53) until it is held in place by the two magnets (39) (on the front of the microtome base plate). To remove the section waste tray, lift it slightly and pull it off towards the back.

6.5 Backlighting

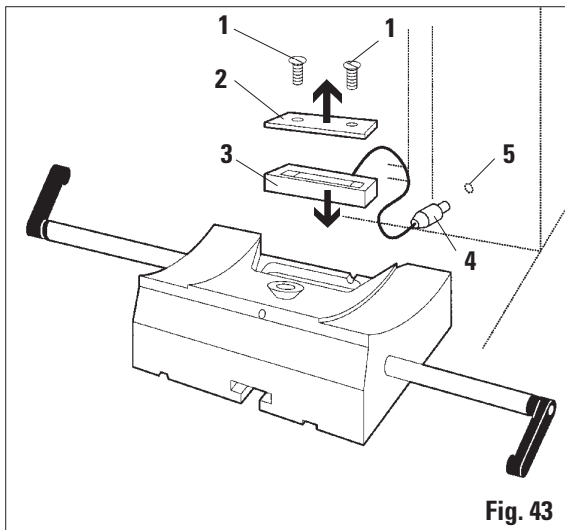

Fig. 43



The backlighting is inserted at the front into the one-piece knife holder base.

- Remove the two screws (1) using a slotted screwdriver and then remove the cover plate (2).
- Insert the backlighting (3) in the recess at the rear of the knife holder base.
- Insert the plug (4) for the backlighting into the socket (5) of the microtome and connect the plug of the power adapter to an AC power socket.

The backlighting illuminates once the microtome is turned on with the mains switch.



NEVER use the backlighting illumination with the super mega-cassette clamp!

6.6 Tray



Fig. 44

The tray is mounted on the hood of the microtome so that the small feet on the underside fit into the cutouts on the hood.

It is for storage of the utensils used during sectioning as well as the sectioned specimens.

6.7 Freezer pack

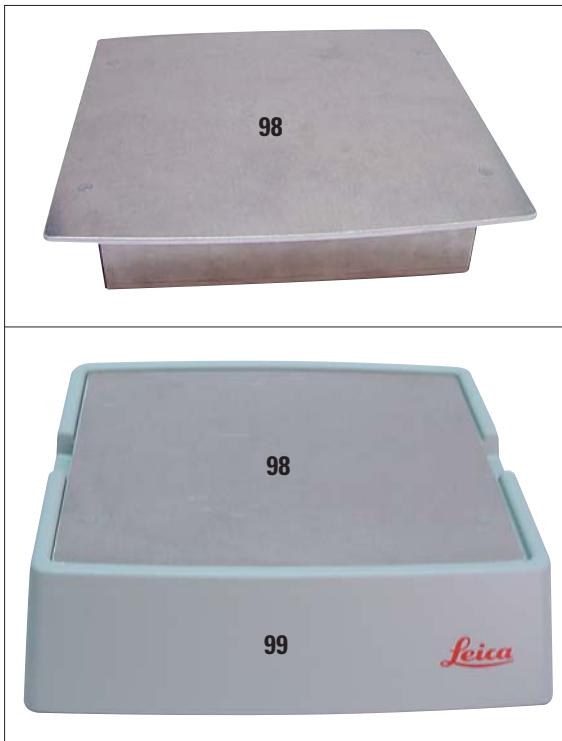

Fig. 45

The freezer pack consists of the freezer plate (98) and the insulation jacket (99). It is for cooling (or keeping cold) paraffin specimens. Up to 35 standard cassettes can be cooled at the same time. The specimens require approx. 20 min. for being cooled from room temperature (approx. 20 °C) to "sectioning temperature".

The cooling performance depends on the ambient temperature and the volume of the specimens being cooled.

The insulation jacket can be placed on the hood of the microtome in the same manner as the tray, or it can be placed next to the instrument.



When using the freezer pack on the instrument the tray (Fig. 44) must be removed.

- Remove the freezer plate from the insulation jacket and place it in a deep freezer, ideally overnight (but for at least six hours) at approx. -23 °C.
- Reassemble the freezer plate and insulation jacket and place them on the bench or the instrument.

6. Optional accessories

6.8 Universal microscope carrier

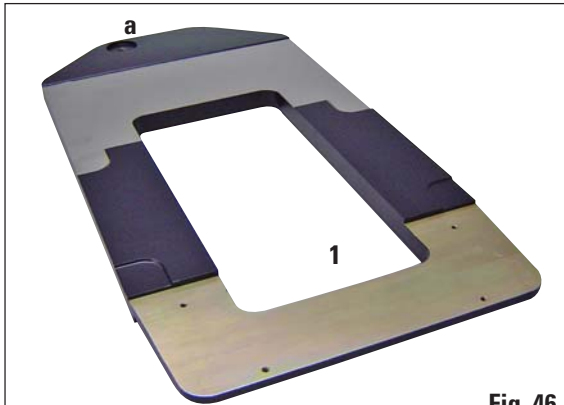

Fig. 46

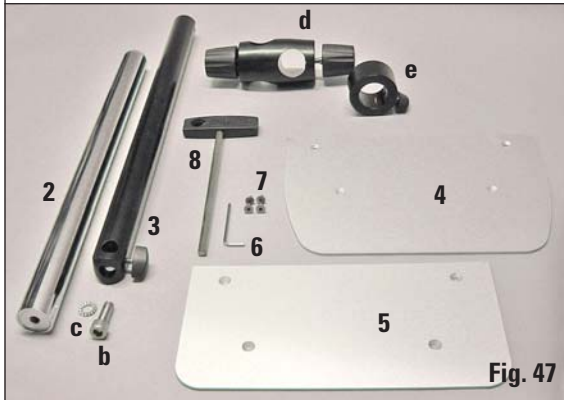

Fig. 47



Fig. 48



Unpack all accessories in the package and check for completeness.

- 1 - Baseplate with drilling (a)
- 2 - Vertical column with size 8 cap screw (b) and lock washer (c)
- 3 - Horizontal arm with cross-member (d) and support ring (e)
- 4 - Support plate, large (for RM2235, RM2245 and RM2255)
- 5 - Support plate, small (for RM2265)
- 6 - Allen key size 3
- 7 - 4 countersunk screws to install support plate
- 8 - Allen key size 8

Assembling the universal microscope carrier

1. Attach baseplate

- Select the large (5) or small (4) support plate, depending on the microtome to be used.
- Attach the support plate to the baseplate with the included 4 countersunk screws (7) using the Allen key size 3 (6).

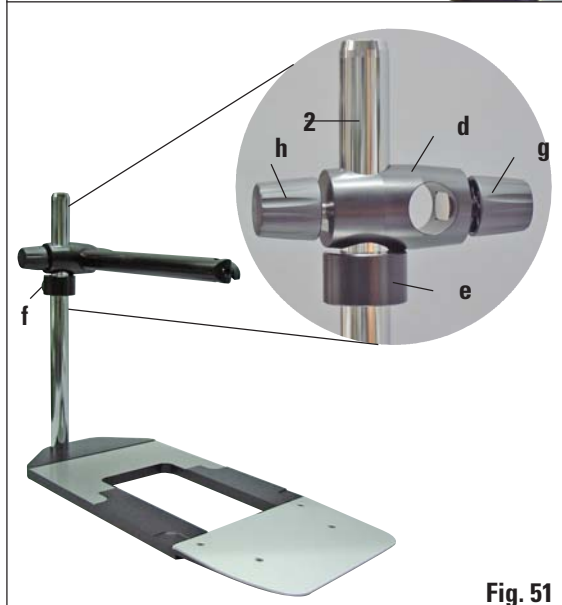
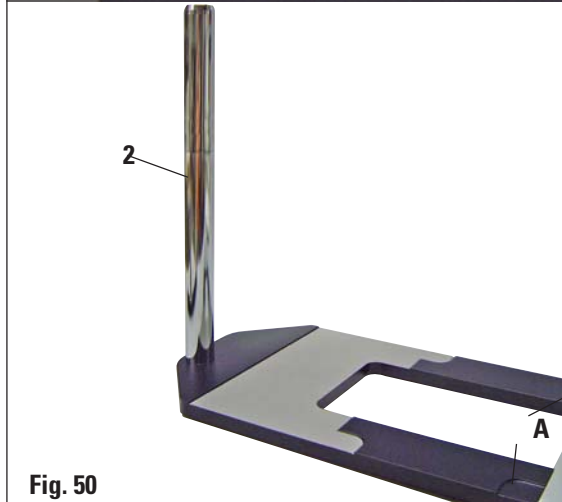
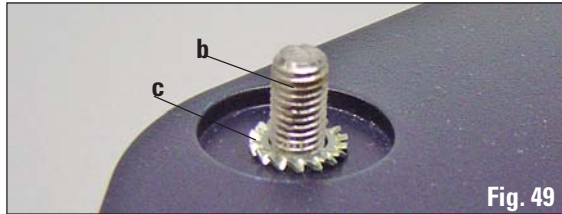

2. Attach vertical column

- Insert the cap screw (b) into the hole of the baseplate from below. Place the lock washer (c) on the cap screw from above.
- Thread the silver vertical column (2) onto the baseplate from above and tighten with the Allen key size 8.



The lock washer must be positioned between the baseplate and vertical column to prevent unintentional turning of the column.



Extreme danger of tipping! After installing the vertical column, immediately place the microtome onto the baseplate so that the front feet of the microtome are positioned in the shallow recesses (A).

3. Attach horizontal arm

- Slide the support ring (e) onto the vertical column and position it so that the lock nut (f) is facing to the back. Tighten the lock nut.
- Slide the cross-member (d) onto the column. Ensure that the lock screw (g) is facing to the right of the baseplate. The horizontal arm must be centered over the microscope.
- Slide the horizontal arm (3), flat side facing the lock screw (g), into the cross-member (d) and tighten.



For more information on connecting and using the microscope, magnifying lens or cold-light source, please see the appropriate manual.

6. Optional accessories

6.9 Magnifying lens



The magnifying lens provides a 2x magnification and can be used with all Leica 2200 series rotary microtomes.

- Open the screw (3) on the horizontal arm of the microscope carrier in a counterclockwise direction.
- Insert the silver connection piece (1) as far as it will go. Tighten the screw (3).
- The adapter (2) allows a fiber-optic light guide to be installed.

- Adjust the position of the magnifying lens to the specimen being processed.
The magnifying lens can be swiveled completely to the side if necessary.



Always protect the magnifier glass from exposure to direct sunlight! Exposure to sunlight may cause a burning glass effect.
Danger of fire!

- Use the provided protective cap (4) to cover the magnifying lens.

6.10 Ordering information

Fixture for specimen clamps, rigid, silver	14 0502 38160
Fixture for specimen clamps, directional, silver	14 0502 38949
Fixture for specimen clamps, directional, with 2 zero point indicators, silver	14 0502 37717
Quick clamping system, complete	14 0502 37718
Knife holder-base rigid, silver	14 0502 37962
Knife holder N RM22xx, silver	14 0502 37993
Knife holder NZ RM22xx, silver	14 0502 37994
Knife holder E narrow band RM22xx, silver, with ejector	14 0502 40508
Knife holder E broad band RM22xx, silver, with ejector	14 0502 40509
Knife holder E narrow band Run-off tray RM22xx.....	14 0502 38961
Knife holder E broad band Run-off tray RM22	14 0502 39114
Knife holder E-TC RM22xx silver	14 0502 37997
Standard specimen clamp with adapter 50x60, silver	14 0502 38005
Standard specimen clamp with adapter 40x40, silver	14 0502 37998
V-insert for Standard specimen clamp, silver	14 0502 38000
Universal cassette clamp, with adapter RM2125 (silver)	14 0502 37999
Universal cassette clamp - ice-cooled	14 0502 37793
Megaclamp assembly RM22xx, silver	14 0502 38967
Foil clamp - type 1, black	14 0402 09307
Foil clamp - type 2, black	14 0402 26922
Round specimen holder, silver	14 0502 38001
Round specimen holder with adapter and 3 clamping rings, silver	14 0502 38002
Clamping ring for round specimen holder, d = 6 mm	14 0356 08322
Clamping ring for round specimen holder, d = 15 mm	14 0356 09200
Clamping ring for round specimen holder, d = 25 mm	14 0356 08320

6. Optional accessories

Universal microscope carrier	14 0502 40580
Magnifying lens assembly	14 0502 42790
Cold light sources	
Leica CLS 100X, 100-120V/50-60Hz	14 0502 30214
Leica CLS 100X, 230V/50-60Hz	14 0502 30215
Leica CLS 100X, 240V/50-60Hz	14 0502 30216
Fiber-optic light guide	14 0502 30028
Backlighting assembly	14 0502 38719
External power supply, complete	14 0500 31244
Handrest for waste tray	14 0502 38770
Cooling device assembly	14 0502 38325
Section waste tray, large	14 0502 37931
Section waste tray, small	14 0503 39060
Demo Box RM22xx series	14 0502 38930
Tray	14 0502 37932
'Leica' brush w/magnet	14 0183 40426
CoolClamp	14 0502 46573



In the following table there is a list of the most common problems which can arise while working with the instrument, along with possible causes and troubleshooting procedures.

Problem	Possible cause	Corrective action
7.1 Possible faults		
1. Thick/thin sections The sections alternate between being thick and thin. In extreme cases, there are no sections whatsoever.	<ul style="list-style-type: none"> • The blade is not clamped properly. • The blade is dull. • The pressure plate is damaged or incorrectly adjusted. • Clearance angle of the knife/blade too small. 	<ul style="list-style-type: none"> • Reclamp the blade. • Laterally displace the knife holder or insert a new blade. • Insert a new pressure plate or use a new knife holder. • Readjust the pressure plate. • Methodically experiment with larger clearance angle settings until you have found the optimum angle.
2. Section compression The sections are very compressed, show folds or are squeezed together.	<ul style="list-style-type: none"> • The blade is dull. • The specimen is too warm. • The sectioning speed is too fast. 	<ul style="list-style-type: none"> • Use another area of the blade or a new blade. • Cool the specimen before sectioning. • Reduce the sectioning speed.
3. "Stripes" in sections For knife holder E	<ul style="list-style-type: none"> • There is an accumulation of paraffin on the rear pressure plate of the knife holder. 	<ul style="list-style-type: none"> • Remove paraffin from this area on a regular basis.
4. Noises during sectioning The knife "sings" when sectioning hard specimens. The sections show scratches or chatter marks.	<ul style="list-style-type: none"> • The sectioning speed is too fast. • The clearance angle is too wide. • Insufficient clamping of object and/or knife holder. 	<ul style="list-style-type: none"> • Turn the handwheel at a slower speed. • Methodically reduce the clearance angle setting until you have found the optimum angle. • Check all screw and clamp connections on the object holder system and the knife holder. If necessary, tighten the levers and screws.
7.2 Instrument malfunctions		
1 There is no further feed motion and thus no sectioning.	<ul style="list-style-type: none"> • The front end position has been reached. 	<ul style="list-style-type: none"> • Run the specimen back by turning the coarse driving wheel.
2. High blade consumption	<ul style="list-style-type: none"> • Too great of a sectioning force was applied. 	<ul style="list-style-type: none"> • Adjust the sectioning speed and/or section thickness when trimming. Select a smaller section thickness, rotate the handwheel more slowly.

8. Cleaning and maintenance

8.1 Cleaning the instrument



Always remove the knife / blade before detaching the knife holder from the instrument.
Always put the knives back into the knife case when not in use!
Never place a knife anywhere with the cutting edge facing upwards and never try to catch a falling knife!
When using cleaners, comply with the safety instructions of the manufacturer and the labor-safety regulations of your laboratory!
When cleaning the outer surfaces, do not use xylene, scouring powders or solvents containing acetone or xylene. Xylene or acetone will damage the finished surfaces!
Ensure that liquids do not enter the interior of the instrument during cleaning!

Before each cleaning carry out the following preparatory steps:

- Raise the specimen clamp to the upper end position and activate the handwheel lock.
- Switch the unit off and unplug it.
- Remove the blade from the knife holder and insert it in the receptacle at the bottom of the dispenser, or remove the knife from the knife holder and put it back in the knife case.
- Remove knife holder base and knife holder for cleaning.
- Remove the specimen from the specimen clamp.
- Remove section waste with a dry brush.
- Remove specimen clamp and clean separately.

Instrument and outside surfaces

If necessary, the varnished outside surfaces of the control panels can be cleaned with a mild commercial household cleaner or soap water and then be wiped with a moist cloth.

To remove paraffin residue, xylene substitutes, paraffin oil, or paraffin removers such as "Para Gard" (Polysciences) can be used.

The instrument must be completely dry before it can be used again.

Cleaning the knife



Always wipe the knife from the back of the knife to the cutting edge. NEVER wipe in the opposite direction - risk of injury!

Clean using an alcohol-based solution or acetone.

Knife holder E

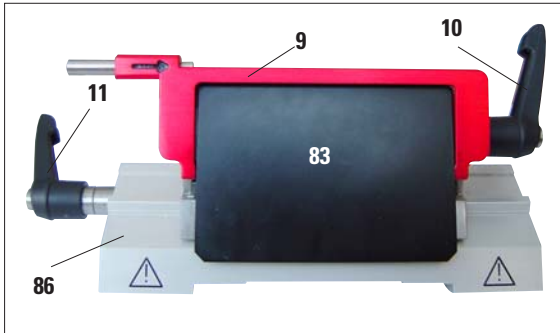

Fig. 55

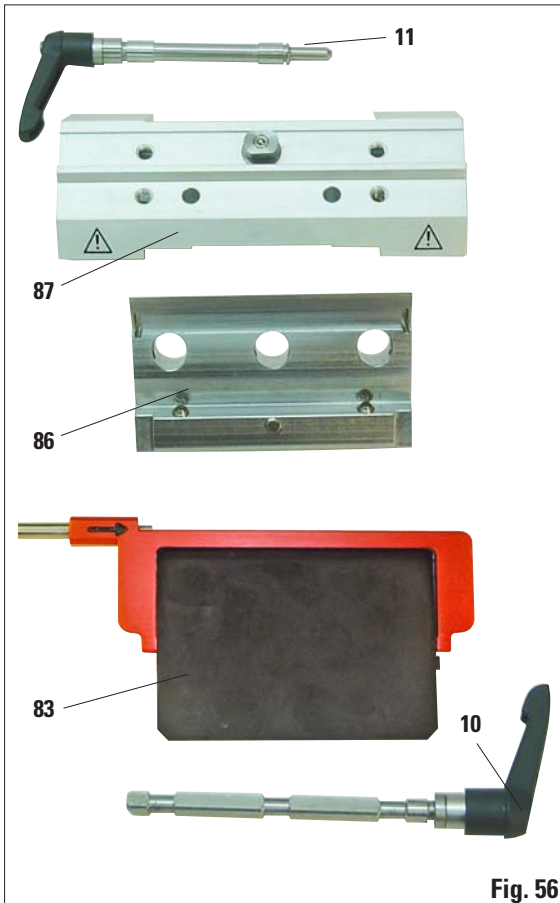

Fig. 56

Take the knife holder apart for cleaning. To do so, proceed as follows:

- Fold knife guard (9) downward.
- Rotate the clamping lever (11) of the lateral displacement forwards and pull it out sideways.
- Push the knife holder base plate (86) with the pressure plate (83) until it can be removed from the segment arch (87).
- Rotate the blade clamping lever (10) downward and pull it out sideways.
- Remove pressure plate (83).
- Clean all parts of the knife holder.



If several knife holders are cleaned at the same time, the parts must not be mixed up!



For cleaning and removal of paraffin, do not use xylene or cleaning fluids containing alcohol (e.g. glass cleaner).

- Dry knife holder and reassemble.
- After cleaning the moving parts, apply a thin coat of drive part oil to them (see also Chapter 8.3).
- When installing the pressure plate (83) make sure that the upper edge is parallel and level with the rear edge of the knife holder base plate (86).

8. Cleaning and maintenance

Universal cassette clamp

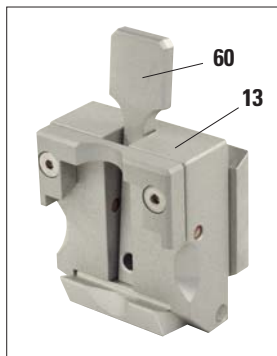

Fig. 57

- Detach cassette clamp (13) for a thorough cleaning, removing all paraffin residues.
- For cleaning, do not use xylene. Use xylene substitutes or paraffin removers such as "Para Gard."
- The cassette clamp (13) can also be placed in an oven heated to a maximum of 65 °C, until the liquid wax escapes.
- Remove paraffin residues with a dry cloth.
- After such a cleaning procedure in an oven, always be sure to lubricate the axle and spring of the clamping lever (60) (see also [chapter 8.3](#)).

8.2 Maintenance instructions



Only authorized and qualified service personnel may access the internal components of the instrument for service and repair!

The instrument is basically maintenance-free. To ensure trouble-free operation of the instrument over a long period of time, the following is recommended by Leica:

1. Thoroughly clean the instrument on a daily basis.
2. Enter into a service contract at the latest at the end of the warranty period. For more information, please contact your local Leica technical service center.
3. Have the instrument inspected on a regular basis by a qualified service technician authorized by Leica.
The intervals depend on how heavily the instrument is used.

We recommend the following inspection intervals depending on the general workload of the instrument as defined in the two categories listed in the table:

	Category I	Category II
Number of sections per day:	> 8.000 sections per day	< 8.000 sections per day
Workload (hours per day):	> 5 hours per day	≤ 5 hours per day
Sectioning speed:	Predominantly high sectioning speed	Slow to medium sectioning speed
Specimen material:	Working with soft and hard specimens	Predominantly soft specimen material
Maintenance:	Every 12 months	Every 24 months

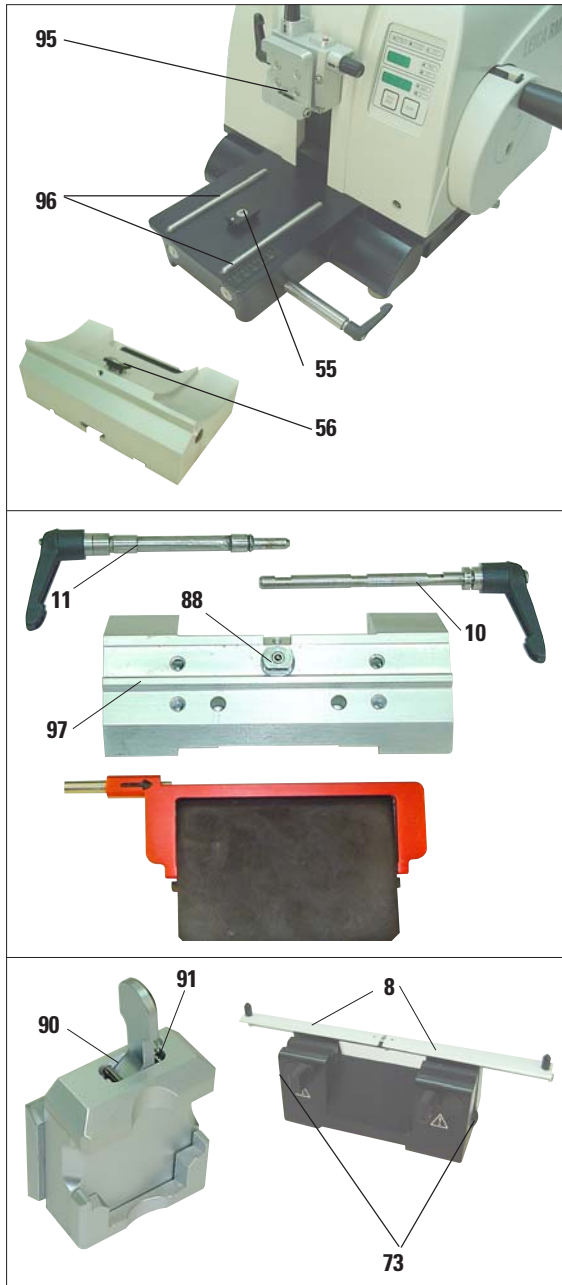

Fig. 58

8.3 Lubricating the instrument

Once a month, lubricate the following parts with the included drive parts oil No. 405 (1 - 2 drops are enough).

Instrument and specimen holder:

- The clamping key (95) of the quick clamping system.
- The T-piece (55) on the microtome base plate.
- Guide rails (96) for the knife holder base on the microtome base plate.
- The T-piece on the knife holder base (56).

Knife holder E:

- Clamping lever (11) for the lateral displacement.
- T-piece (88) and guide (97) of the knife holder for the lateral displacement.
- Clamping lever (10) for the blade.

Knife holders N and NZ:

- Sliding surfaces of the finger guard (8).
- Knurled nuts (73) for measuring height adjustment.

Universal cassette clamp:

- Shaft (90) and flat coil spring (91) of the clamping lever of the cassette clamp. After lubrication, move the lever back and forth several times.

9. Warranty and service

Warranty

Leica Biosystems Nussloch GmbH guarantees that the contractual product delivered has been subjected to a comprehensive quality control procedure based on the Leica in-house testing standards, and that the product is faultless and complies with all technical specifications and/or agreed characteristics warranted.

The scope of the warranty is based on the content of the concluded agreement. The warranty terms of your Leica sales organization or the organization from which you have purchased the contractual product shall apply exclusively.

Service information

If you are in need of technical customer service or spare parts, please contact your Leica representative or the Leica dealer where you purchased the instrument.

Please provide the following information:

- Model name and serial number of the instrument.
- Location of the instrument and name of the person to contact.
- Reason for the service call.
- Delivery date.

Decommissioning and disposal

The instrument or parts of the instrument must be disposed of according to existing local applicable regulations.